

PROFESSIONAL DEVELOPMENT

AP[®] Physics
Conservation Concepts

Curriculum Module

The College Board

The College Board is a mission-driven not-for-profit organization that connects students to college success and opportunity. Founded in 1900, the College Board was created to expand access to higher education. Today, the membership association is made up of more than 5,900 of the world's leading educational institutions and is dedicated to promoting excellence and equity in education. Each year, the College Board helps more than seven million students prepare for a successful transition to college through programs and services in college readiness and college success — including the SAT® and the Advanced Placement Program®. The organization also serves the education community through research and advocacy on behalf of students, educators and schools.

For further information, visit www.collegeboard.org

Contents

Introduction	1
Systems	5
Conservation of Energy	9
Conservation of Linear Momentum	25
Conservation of Angular Momentum (for Physics C: Mechanics)	29
Conservation of Mass	33
Conservation of Charge	37
References	43
Appendixes	45
About the Contributor	89

Equity and Access Policy

The College Board strongly encourages educators to make equitable access a guiding principle for their AP® programs by giving all willing and academically prepared students the opportunity to participate in AP. We encourage the elimination of barriers that restrict access to AP for students from ethnic, racial, and socioeconomic groups that have been traditionally underserved. Schools should make every effort to ensure their AP classes reflect the diversity of their student population. The College Board also believes that all students should have access to academically challenging course work before they enroll in AP classes, which can prepare them for AP success. It is only through a commitment to equitable preparation and access that true equity and excellence can be achieved.

Introduction

By Connie Wells
Pembroke Hill School
Kansas City, Missouri

Conservation laws describe the possible motions and interactions of objects and systems and can be used to predict the outcomes of interactions or processes. Conservation is one of the common links throughout the study of physics, so the topic for this Curriculum Module has been selected to illustrate an approach to teaching physics where major themes are repeated as basic conceptual understandings, or “Big Ideas.” The “Big Idea” of conservation has a few simple rules — starting with the identification of a system — that can be applied by students as they approach different topics of study.

Conservation principles may be taught with greater understanding through an integrated approach that merges conceptual understanding with development of scientific and cognitive skills. Developing this depth of understanding requires recognition by the teacher that no topic or concept stands alone: It is the integration of related concepts, along with development of cognitive skills, that leads the student to an authentic depth of understanding.

This AP[®] Curriculum Module is designed around the conservation concepts that students will encounter in AP Physics. Each major concept, and the enduring understandings for that concept as outlined by the curriculum, is listed in each section. A description of common misunderstandings that students bring to this topic, as well as some suggested teacher and student activities, are included, along with some applications of that concept to what students see and read about every day.

When developing a lesson for one of the conservation concepts, the teacher should consider the following elements of a “cycle of learning”:

- Plan teaching activities that deal with the concept and its enduring understandings as outlined in the course’s learning objectives found on the AP Physics home pages on AP Central[®]. Consider each concept within the context of related concepts and how students’ understanding can be enhanced by developing links among concepts throughout the year.

- Revise the plan as necessary to address students' misconceptions, gaps in prior knowledge of the subject, and variations in skill levels and learning styles. Examples of these misconceptions are provided for each major concept.
- Teach the concept by using a variety of approaches, including teacher-directed discussions and demonstrations, visual presentations, student laboratory work, and small-group work.
- Assess student understanding frequently through formative assessments such as lab journal analyses with targeted questions, class discussions, and group work in class.
- Reflect on the lesson to consider how teaching methods may be adjusted for future lessons in order to address lingering misconceptions revealed in assessments.

Teaching Activities

The teacher should use a variety of activities in the classroom and in the laboratory to teach and reinforce concepts. Presenting concepts to students through a variety of methods better addresses the range of modalities by which students best learn. Redundancy in instructional strategies and learning opportunities serves to reinforce a concept or skill in different ways and ensures that each student is more likely to have engaged with the instruction in a way that enables him or her to better understand the targeted concepts. For example, students who have difficulty with note-taking — as well as students who are visual learners — may best benefit from a PowerPoint presentation that includes definitions of terms, careful wording of the basic concepts, equations that will be used in that lesson, diagrams or downloaded photos that illustrate applications of the concept, and sample problems that illustrate methods of solution. Students who are strong mathematically may benefit from problems worked on the board, either by students who then present their solutions or by the teacher, who asks frequent questions. Laboratory activities appeal to kinesthetic learners who grasp the concept by manipulating equipment and making direct observations of “how things work.” The laboratory journal is a place for strong writers and those with artistic talent to show their skills in representations of setups and observations and in summarizing their thoughts and observations in the analysis. (Refer to the Laboratory Report Format in Appendix A for more ideas on how to use the journal for teaching and assessment.) Some students learn well from other students, so those needs are met both by working in small groups in the laboratory and by small-group formative assessment activities during class.

Formative Assessments

Formative assessments — those methods by which teachers determine daily how students are progressing in their learning — can take different forms in a lesson:

1. The teacher may collect and read the laboratory journal analyses of teacher-directed activities or student laboratory experiments, watching for misstatements, erroneous conclusions, incorrect calculations, incorrectly constructed graphs, and incorrectly drawn diagrams.
2. During teacher demonstrations, getting students involved in a dialogue during each step of the demonstration will lead to both correct and incorrect conclusions from observations. Preparing meaningful questions in advance of the demonstration will elicit student responses and assess understanding of concepts. The key is not to discourage student responses with a “that’s wrong” reply but instead to use a response such as: “I’m glad you brought out that point, because that’s a common error and we really need to discuss it.”
3. The teacher may select released AP Physics Exam free-response problems that involve decision making about the use of formulas and applications of concepts. These are easily available at http://apcentral.collegeboard.com/apc/members/exam/exam_information/2007.html. The teacher may assign students to work in small groups on the solution, giving them about 20 minutes to hand in a “group” paper. A member of the group may go to another group to ask a question and bring the answer back to their own group. As this is happening, the teacher should walk through the class, making observations and answering questions (but not providing answers to the problem).
4. A well-designed formative assessment provokes thinking that requires application of concepts to new situations. See Appendix F for a sample related to conservation of charge.

Schematic for lesson development

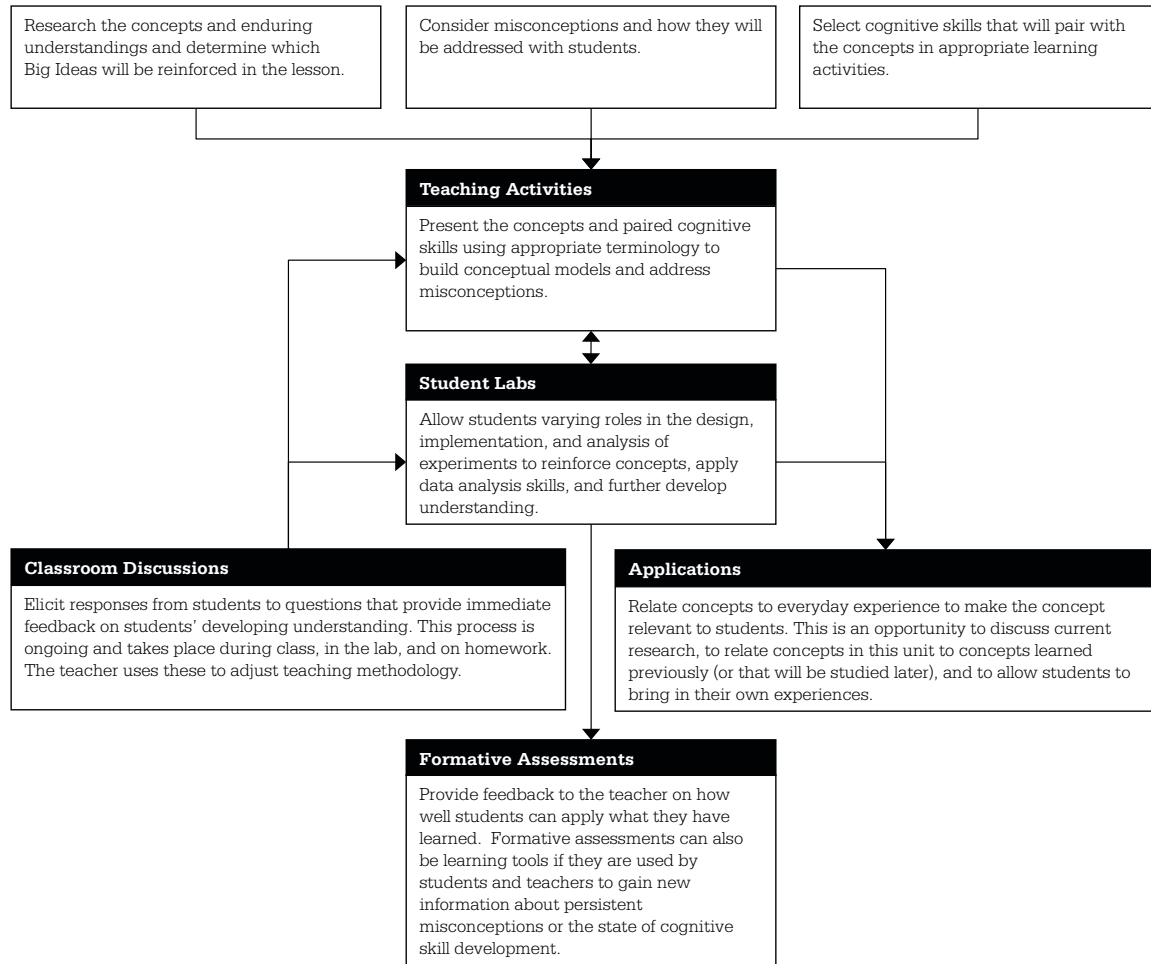

Figure 1

Systems

Introduction

Once students learn to define a system and apply conservation of energy, linear momentum, angular momentum, mass, and charge to that system, the physics makes sense in terms of “Big Ideas” that can be applied to many different situations. It is important, then, before embarking on a study of any of the conservation concepts, to learn to define the system under consideration. Students will need practice with this: learning to take given scenarios and define the system in the best way to solve a given problem, which they will apply throughout their study of physics.

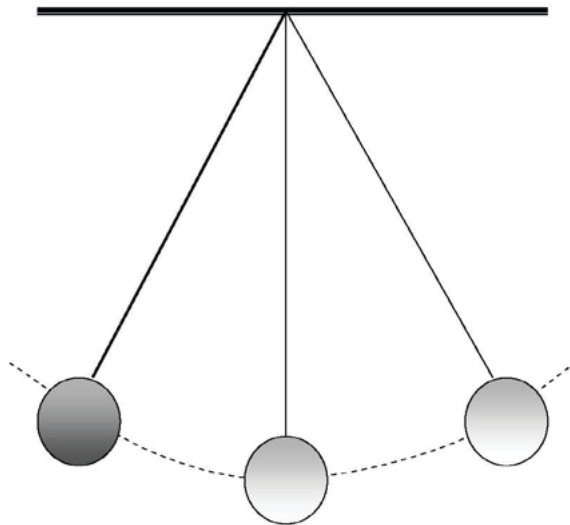

Figure 2

Concept

Certain quantities are conserved, in the sense that the changes of those quantities in a given system are always equal to the transfer of that quantity to or from the system by all possible interactions with other systems.

Enduring Understandings

A system is an object or a collection of objects. The objects are treated as having no internal structure.

1. For all systems under all circumstances, energy, charge, linear momentum, and angular momentum are conserved. For an isolated or closed system, conserved quantities are constant.
2. An interaction can be either a force caused by other objects outside the system or the transfer of some quantity with objects outside the system.
3. The boundary between a system and its environment is a decision made by the person considering the situation.

Common Misconceptions

Students have some difficulty isolating systems, particularly when considering whether the system is open or closed. Some clarification of this comes from practice with free-body diagrams, where students must be reminded to isolate an object and draw only the forces on that object and not to consider forces the object exerts on other objects inside or outside the system. When studying forces, it is often helpful to consider a “system approach” to multiple objects, such as boxes in contact on a surface or objects hanging from a string over a pulley. This application of system identification in the unit on forces may set the stage for better understanding of systems when energy conservation is studied.

The situation shown in Figure 2, above, for a ball of uniform density oscillating on a massless string could be described as a closed system consisting only of the ball, string, and Earth, in order to apply conservation of energy. At a given height prior to release, the ball-Earth system has a certain potential energy due to their relative positions. At that point, the only forces are within the system: the tension of the string on the ball and the gravitational forces between the ball and Earth. The total mechanical energy (potential energy and kinetic energy) of the system is constant, so a decrease in gravitational potential energy as the ball swings closer to Earth results in an increase in kinetic energy of the ball. Later in the course, students will further develop their understanding of gravitational potential energy, defining it as a negative quantity that is derived from gravitational force. Here, they will define the gravitational potential energy of an object in an object-Earth system as having zero total mechanical energy if it is released at an infinite distance from Earth. Then as the object “falls” toward Earth, its gravitational potential energy decreases by becoming increasingly negative as its kinetic energy becomes increasingly positive — and the sum of the two is constant (zero).

Defining the system differently — as the ball and Earth without the string — leaves the tension of the string outside of the system. This force, external to the system, changes the configuration of the system (i.e., the tension in the string varies with the position

of the ball relative to the Earth). This definition is convenient for the definition of a simple pendulum at small angles of oscillation as a harmonic oscillator (i.e., that the restoring force is proportional to the displacement of the ball from its equilibrium position).

The situation given might be a solid uniform ball attached securely to a solid uniform rod attached at a pivot point. If the student is asked to determine the angular velocity of the ball and rod at its lowest point, the system should be defined as the ball and rod so the moment of inertia of the system can be determined. Again, if the potential and kinetic energy changes of the ball-rod pendulum are to be determined, the Earth should be included in the system so that the system has gravitational potential energy.

Summary

This section introduced the concept of systems, offering a clear distinction between open and closed systems and the importance of defining a system appropriately when solving problems or analyzing situations that conserve quantities. Isolating a system for study is basic to applications of concepts and solutions of many types of problems in physics. Since this is a concept that underlies other lessons to follow, the concept itself lacks a context, so it is important to constantly reiterate the importance of systems in each new context. The teacher would not do much more here than define systems and provide some examples of how systems and the ability to define systems will be important in lessons to follow. The concepts learned in this section will recycle throughout the study of physics, because identification of a system is important, not only for the study of all the conservation laws that follow in this module but also for the study of forces and interactions and other important areas of physics.

Conservation of Energy

Introduction

For all systems under all circumstances, energy, charge, linear momentum, and angular momentum are conserved. For open systems, changes of these quantities are equal to the transfer of each quantity to or from the system by interactions with other systems. For an isolated or a closed system, conserved quantities are constant. The concept of conservation applies throughout physics and should be used as a common theme that helps students approach new topics of study. Students will bring some understanding of energy conservation principles as they are applied in chemistry, biology, and environmental science. Energy conservation principles also underlie many areas of physics: gravitational systems, springs and pendulums, thermodynamics, fluid flow, electrical circuits, nuclear equations, mass-energy conversions, and photoelectric effect.

Concept

The energy of a system is conserved.

Enduring Understandings

1. Classically, an object can only have kinetic energy.
2. A system with internal structure can have internal energy.
3. A system with internal structure can have potential energy. Potential energy exists within a system if the objects within that system interact with conservative forces.
4. The internal energy of a system includes the kinetic energy of the objects composing the system and the potential energy of the configuration of the objects composing the system. Since energy is constant in a closed system, changes in a system's potential energy result in changes in the kinetic energy.
5. Energy transfer can be caused by a force exerted through a distance; this energy transfer is called work.

6. Energy can be transferred by thermal processes involving differences in temperature; this process of transfer is called heat.
7. The First Law of Thermodynamics is a specific case of the law of conservation of energy involving the internal energy of a system and the possible transfer of energy through work and/or heat.
8. Energy transfer occurs when photons are absorbed or emitted, for example by atoms or nuclei.
9. Kirchoff's loop rule describes conservation of energy in electrical circuits.
10. Bernoulli's equation describes the conservation of energy in fluid flow.
11. Beyond the classical approximation, mass is actually part of the internal energy of an object or system with $E = mc^2$.

Common Misconceptions

Work is a transfer of energy into or out of a system by an external force. Work done on a system increases the total energy of the system and is generally called *positive work*. However, in the context of thermodynamic systems, many textbooks reverse this terminology as a long-held convention, defining positive work as that done *by* the system, which reduces the system's energy (a statement of the First Law of Thermodynamics). This is confusing for students, particularly those who may also be taking classes in Chemistry, where the "positive work/positive energy change" convention is often held. It's best to address this confusion directly, point out the convention differences, and assure students that as long as they are clear on the concepts, the sign convention is irrelevant.

To better consider individually the various contexts in physics in which energy conservation applies, these topics are addressed separately in this lesson.

Instructional Activities

Activity 1: Energy in Gravitational Systems

Common Misconceptions

Students often have difficulty with the idea of path-independence for conservative forces and path-dependence for nonconservative forces. The teacher will need to use examples, illustrations, and assigned sample problems of each to clarify these concepts for students.

Students may come to the topic with a simplistic view of gravitational potential energy as a property of a single object. It should be emphasized to students that potential energy is due to the relative positions of two objects. They may also have an unclear understanding of how frame of reference is defined for "zero gravitational potential

energy.” For example, a ball lifted above the floor has gravitational potential energy only due to its position relative to the Earth; as the ball’s position relative to Earth changes, its gravitational energy changes. The teacher can counter misconceptions by bringing in many different examples — using different frames of reference — and clarifying that the frame of reference simplified problem solving. In most cases, the solution is based upon differences in potential energy and not an absolute value (i.e., gravitational potential energy calculated from center-to-center distance between Earth and an object).

Teacher-Directed Activities

A deeper understanding of gravitational potential energy can be facilitated by the teacher’s use of many different examples to illustrate how gravitational potential energy and kinetic energy are related (i.e., dropping a lot of things, such as rubber balls, as you present the topic).

Students can develop a model for conservation of energy using the analogy of a balanced budget. The bank could be compared to a closed system, with a savings account compared to potential energy and a checking account to kinetic energy. Monetary transfers from one account to another keep the funds in the bank constant — as long as the bank is closed. A transfer of funds from savings to checking decreases one and increases the other, while the total remains constant. When the bank is open, however, exchanges of deposits or withdrawals with the outside world that change the total funds in the bank could be compared to work done on the open system. Yet, the good banker keeps track of all these exchanges, accounting for every transfer. This is comparable to a conservation law for money: No money is created or destroyed; the transfer of money in is equal to the increase in accounts in the bank, and the transfer of money out is equal to the decrease in accounts in the bank.

Graphs are important tools used by physicists and engineers to process data or examine relationships between variables. Figures 3 and 4 show the values of energy and potential/kinetic energy relationships for a 1.0 kg object falling in the gravitational field near Earth’s surface (i.e., acceleration is $9.8 \frac{m}{s^2}$) from a height of 30 meters. Students should recognize from the relationships in Figure 3 that gravitational potential energy decreases linearly with height as an object falls, so its kinetic energy increases linearly as the object falls, keeping the total mechanical energy of the Earth-object system constant (in the absence of an external force, such as friction).

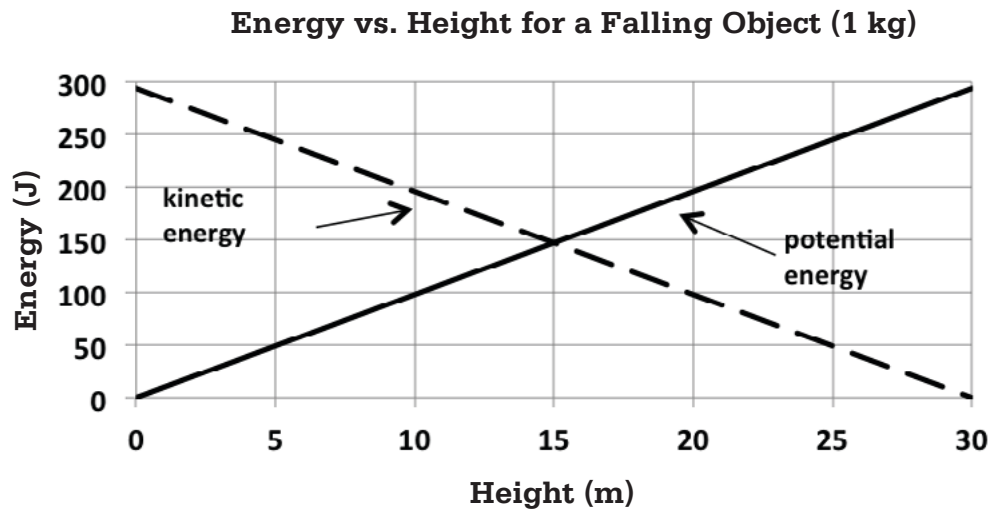

Figure 3

In Figure 4, it should be pointed out that kinetic energy increases as the square of time as an object falls, since it is undergoing constant acceleration — increasing the velocity linearly — but velocity is squared to find kinetic energy. Thus, the potential energy decrease is also a curve — determined by insight into the fact that the total energy must remain constant — or examined mathematically (i.e., the displacement of the object downward varies as the square of time: $s = v_0t + \frac{1}{2}gt^2$).

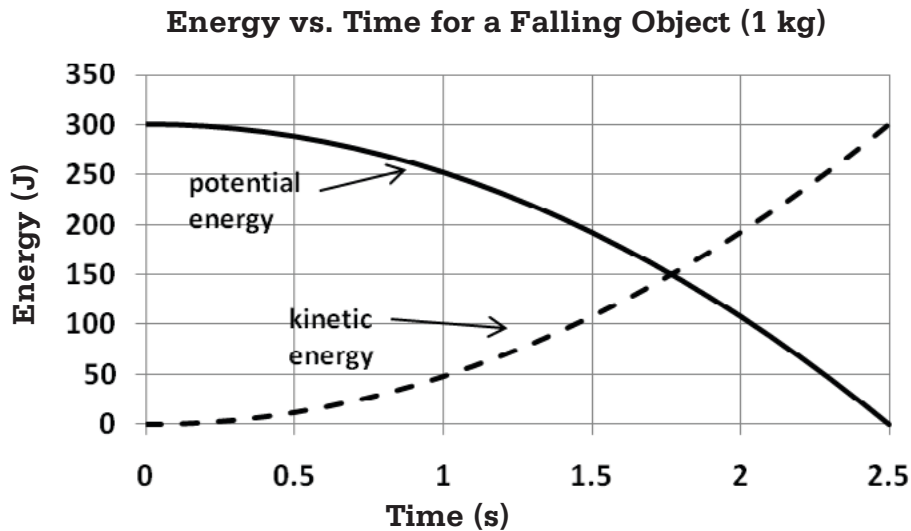

Figure 4

Student Laboratory Work

Laboratory measurements allow students the opportunity to quantify conservation of energy or to determine when mechanical energy is conserved. Sometimes the same equipment or the same basic experiment can be used in those programs offering a two-year sequence by adding concepts in the second course or by using an assumption

(such as no friction) in experiments from the earlier lab to examine or quantify those assumptions to create a more advanced laboratory investigation. (See Appendix A).

Energy for a Ball on a Ramp

- In an introductory course, gravitational potential energy and translational kinetic energy calculations of a ball on a ramp are used to determine speed of the ball as it leaves the ramp. That speed is used to determine the position of the ball when it lands on the floor.
- For more advanced students, using the same equipment, an experiment is designed in which gravitational potential energy, translational kinetic energy, and rotational kinetic energy calculations of a ball on a ramp are used to estimate an average value for the coefficient of kinetic friction. (See Appendix B.)

Activity 2: Energy in Spring-Mass Systems

Common Misconceptions

The spring force is a variable force, not a constant force. By Hooke's Law, the spring force increases as the force applied to it increases. At times, students may erroneously think of the spring force as a constant force. In calculating work done on a spring, for example, students may want to use "force multiplied by distance," but this would be incorrect. They must use the product of average applied force and distance, best explained graphically, as in Figure 5:

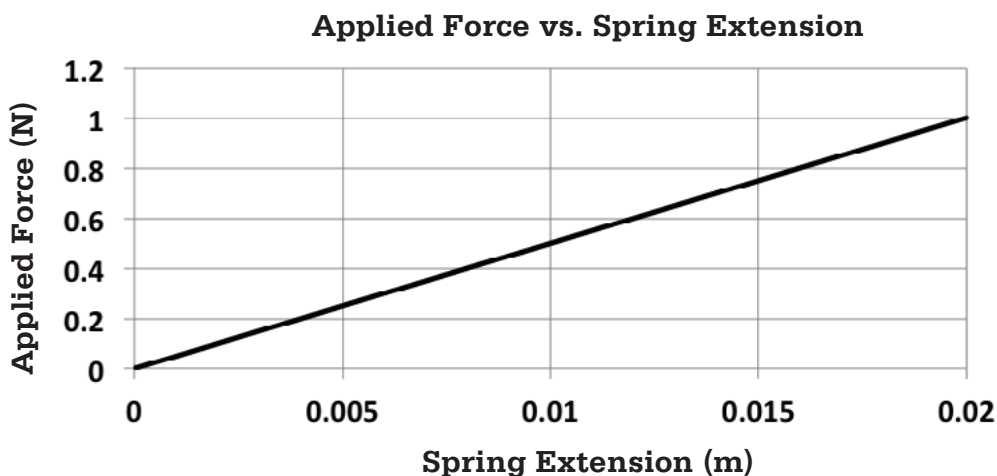

Figure 5

Students are often not clear on the idea that the oscillation of a spring between different positions (and energy states) is caused by a combination of the net force when the spring is not at equilibrium and the inertia (which is not a force) of the attached object that keeps it moving past the equilibrium position. At the equilibrium position, there is no net force on the attached mass.

Teacher-Directed Activities

When oscillatory motion of springs is introduced, make a comparison between the gravitational potential energy of a ball at the top of a ramp and the elastic potential energy of a spring. Show how the methods of determining kinetic energy where it is a maximum (at the bottom of the ramp or at the equilibrium position of a spring) are essentially the same.

As a challenge to students, demonstrate an “inertial balance” to show how the potential energy is developed by positioning the masses horizontally. This is just another type of spring on which one places different masses (see Figure 6), which produce different periods of oscillation, and also demonstrates conversions of potential to kinetic energy as it oscillates.

$$T = 2\pi\sqrt{\frac{m}{k}} \text{ and } U = \frac{1}{2}kx^2.$$

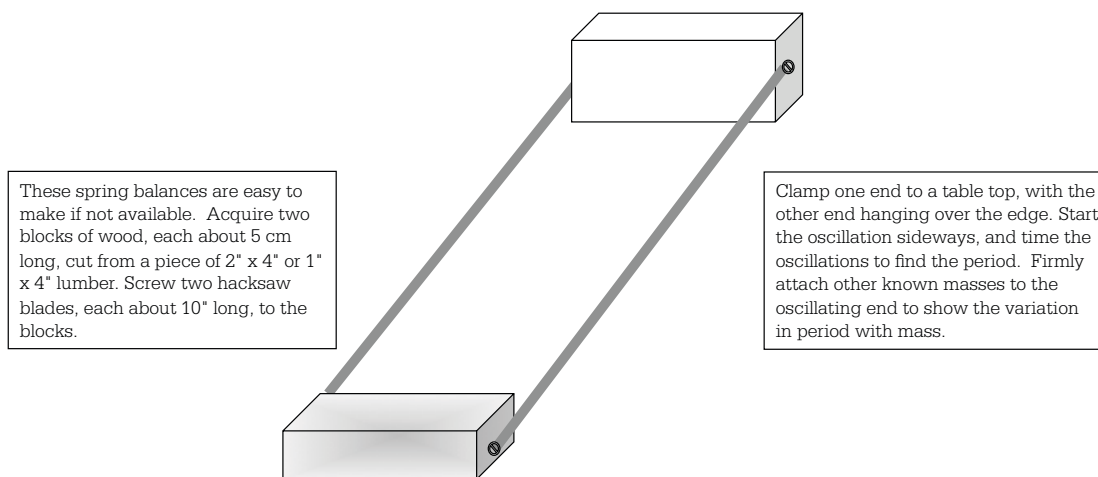

Figure 6

Use a graph of *Force vs. Displacement* of a spring to show students that the calculation of work done in stretching the spring a distance x would have to use the product of the **average** force, since the force is variable. The work done in stretching the spring can be calculated from the formula or can be determined from the area under the plot line. That's a triangle — one-half base times height — or $\frac{1}{2}Fx$. But $F = kx$, so the substitution of kx

for F yields an area of $\frac{1}{2}(kx)(x)$ or $\frac{1}{2}kx^2$. That's the equation for potential energy of the spring:

$$U = \frac{1}{2}kx^2$$

The work done on the spring is equal to the potential energy of the spring. The slope of the line is the spring constant or the k value; for example, for a force of 1 newton applied to a spring to extend it 20 cm:

$$k = \text{slope} = \frac{1 \text{ N}}{0.02 \text{ m}} = 50 \frac{\text{N}}{\text{m}}$$

Now we can calculate the potential energy of the spring, which is the work done on the spring, or the area between the graph line and the x-axis. (See Figure 5.)

$$W = U_s = \frac{1}{2} kx^2 = \frac{1}{2} (50 \frac{\text{N}}{\text{m}})(0.02 \text{ m})^2 = 0.01 \text{ J}$$

Student Laboratory Work

Plotting Harmonic Motion

A motion sensor directed at a mass on a spring (connected to a calculator or computer) can plot position, velocity, and acceleration as functions of time. Students would examine the plots to determine period, frequency, position amplitude, and relative positions of maxima for position, velocity, and acceleration. Students can also determine position amplitude directly to calculate potential energy maximum, then determine velocity amplitude directly. Calculations are made to illustrate conversions of mechanical energy.

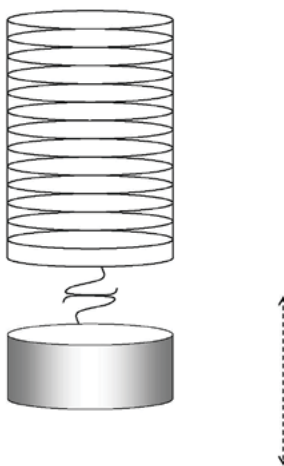

Figure 7

Applications

Students encounter oscillating springs every day, from garage door springs that store spring potential energy when the door is lowered (with the help of gravitational force) so that the spring can help do the work of lifting the door (saving work by the lifting motor), to spring-

loaded toys and the shock absorbers in a car. Since springs will behave in space according to the same equations (point out that “g” is not in the equation to calculate the period of a spring), a torsional spring chair can be used to find the mass of astronauts in space.

The basic concepts of harmonic motion will be applied later in the study of mechanical wave oscillation, and the terms *period*, *frequency*, and *amplitude* will be applied to the study of all types of waves. Springs will also be studied under the section on forces.

Activity 3: Thermodynamics

Concept

Energy can be transferred by thermal processes involving differences in temperature; this process of transfer is called heat.

Enduring Understandings

The First Law of Thermodynamics is a specific case of the law of conservation of energy involving the internal energy of a system and the possible transfer of energy through work and/or heat. Students should be able to either construct plots of *Pressure vs. Volume* (PV diagrams) from given information or answer questions (qualitative and/or quantitative) from a PV diagram. The terminology involved includes *isovolumetric*, *isothermal*, *isobaric*, and *adiabatic processes*, and calculations include use of the ideal gas equation, the First Law of Thermodynamics, and calculations of work using pressure and change in volume.

Common Misconceptions

The term “heat” may be used incorrectly as something an object or system contains. Heat should be defined as a transfer of energy from an object or system with higher temperature to an object or system with lower temperature. Students will misuse the term “heat” unless the teacher is very careful with how the term should be used.

The sign on work in thermodynamic systems is often confused, perhaps because the convention for the sign on work is different for different books. The teacher can clarify this with careful energy “bookkeeping,” with or without a statement of the First Law of Thermodynamics. Work done *on* a system will *increase* its energy. Work done *by* a system will *decrease* the system’s internal energy and/or come from heat transferred to the system. (If a process is isothermal, the internal energy of the system does not change, so work done on or by a system will result in heat transfer from or to the system, respectively.)

Sign Convention for Calculations of Work

The sign convention for the First Law of Thermodynamics is consistent with most chemistry texts and with the convention wherein *work done on a system is positive*. However, many physics texts do not use this convention, so it is important for teachers and students to review the concept of work and the consistency of sign conventions that

this change represents overall. The review below summarizes this sign convention and compares it to the same convention used in other contexts.

Using this convention, the First Law of Thermodynamics is given in the form $\Delta U = Q + W$. For consistency, the formula for work done on the system is $W = -P\Delta V$ when the volume changes at constant pressure, P .

Mechanical work done against a gravitational force:

- Work done *against* gravity (e.g., in lifting an object) is *positive* work.
- Work done *with* gravity (e.g., in lowering an object) is *negative* work.
- Positive work done on a system increases the potential energy of that system.
- $W = F_s \cos \theta$, where maximum work is done when the external force doing the work and the displacement are in the same direction.

Mechanical work done against a spring force:

- Work done in stretching or compressing a spring (i.e., work done against the spring force) is positive work.
- Positive work done on a spring-mass system increases the potential energy of that system.
- $W = \Delta U = \frac{1}{2} kx^2$

Mechanical work done against an electrical force:

- Work done in moving a positively charged particle toward another positively charged particle (i.e., against the electric field lines and against the electric force on that particle) is positive work. Likewise, work done in moving a negatively charged particle toward another negatively charged particle is positive work.
- Positive work done in each case increases the potential energy of the system.
- $W = \Delta U = q\Delta V$, where the electric potential changes, ΔV , and the charge, q , is constant.
- If q is positive, positive work is done when ΔV is positive (i.e., the particle is moved from lower potential to higher potential, as is the case when moving toward another positive charge). If q is negative, positive work is done when ΔV is negative (i.e., the particle is moved from higher potential to lower potential, as is the case when moving toward a negative particle).

Work done on a thermodynamic system:

- Work done in compressing a system of ideal gas particles is positive, since it increases the potential energy of the system of particles.
- Since $W = -P\Delta V$, when volume decreases at constant pressure, ΔV is negative and work done is positive.
- $\Delta U = Q + W$, where $+W$ is work done *on* the system. Positive work produces a positive ΔU , and $+Q$ is heat added to the system, so it also produces a positive ΔU .

Teacher-Directed Activities

Plots of ideal gas pressure as a function of volume (called P-V diagrams) are the physicist's and engineer's tool for system analysis. Students have difficulty with these, so time should be spent "walking" students step-by-step through such a diagram analysis. The student might be given a situation in which 1 mole of an ideal gas goes through a process in the three stages, as indicated by I, II, and III on the P-V diagram in Figure 8. The student should be able to use values from the diagram to answer questions or make calculations about the types of processes involved and the pressure, volume, and temperature at various points on the diagram. This should be an interactive process with students so that the teacher explains concepts as well as gets immediate feedback from students as steps are taken through the plot.

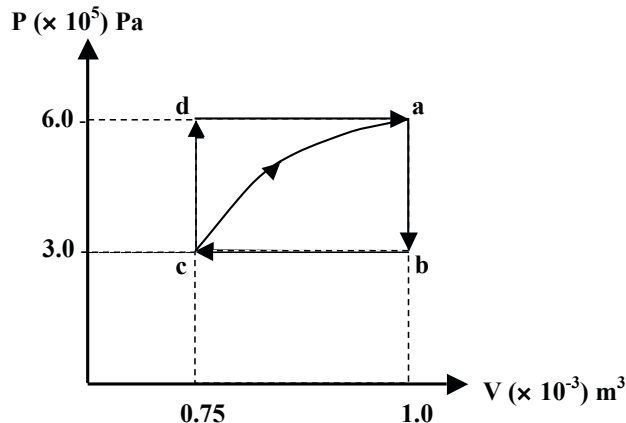

Figure 8

Problem 5 from the 2003 AP Physics B published exam (http://apcentral.collegeboard.com/apc/public/repository/ap03_frg_physics_b_23086.pdf) provides a P-V diagram with similar tasks that could be used to assess students' understanding of concepts.

Student Laboratory Work

Using a commercial apparatus called the "Electrical Equivalent of Heat" experiment, students connect an electrical circuit to a lightbulb constructed to be safely immersed

in water. Various measures are taken to “close” the system so that heat is not transferred to the environment. Students calculate the energy in Joules produced by the electrical circuit during a given time period and then use the temperature change of the water and apparatus to calculate the heat in calories transferred. A numerical value close to 4.184 J/cal is obtained. The goal is to discuss various methods of heat transfer to environment, along with measures taken to reduce heat transfer by those methods. (Note: This experiment could be done more simply with an electric immersion heater for cups of water. Use the wattage marked on the heater and the time it is on as the input energy. Calculate the temperature change of the water and use that as the ΔT in the equation $Q = mc\Delta T$ to determine the approximate heat transfer to the water.)

Applications

Thermodynamic systems such as refrigerators, air conditioners, and automobile engines can be made to run more efficiently by studying the energy input and energy output, using something similar to P-V diagrams (likely computerized). As we become more conscious of fuel conservation, the development of energy-saving technology involves very important research that requires knowledge of thermodynamic processes.

Activity 4: Electrical Circuits

Concepts

Kirchhoff’s loop rule describes conservation of energy in electrical circuits. Since electric potential difference multiplied by charge equals energy, and energy is conserved, the sum of the potential differences about any closed loop must add to zero. The electric potential difference across a resistor is given by the product of the current and the resistance. Circuits with resistors and capacitors are treated qualitatively for time-varying circuits (i.e., questions about how current and charge on capacitor vary with time) and quantitatively for steady-state circuits (i.e. calculations of current, potential difference, capacitance, or charge after the circuit has run for a long time and the capacitor is fully charged).

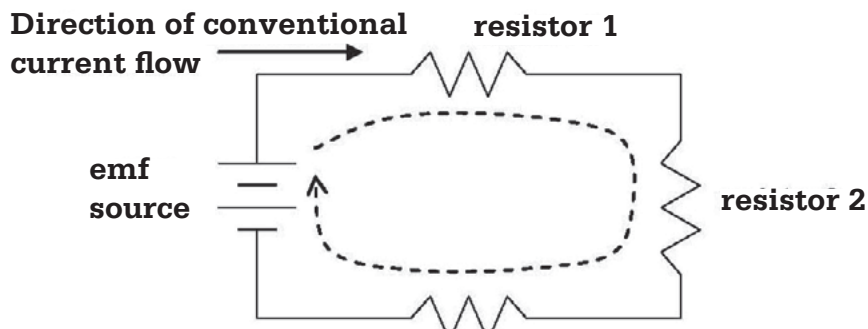

Figure 9

Common Misconceptions

Some students believe that changing the order of components in a series circuit will somehow change the current in or potential difference across these components. Teacher demonstrations in which the order of connections can be manipulated and discussed (such as the “Determining Wattage” demo) and student labs in which students make observations and measurements in circuits for different configurations will help to dispel this belief.

Related to this concept, students also have misconceptions about the nature of current, often believing that current is somehow “used up” to produce energy. This is addressed by the lesson in Section VII.

Teacher-Directed Activities

The “Determining Wattage” interactive demonstration addresses conservation of energy in electrical circuits and includes formative assessment questions. (See Appendix C.)

The student laboratory activity for “Introduction to Electrical Circuits” (see Appendix D) describes a hands-on experience in constructing circuits and taking measurements to dispel misconceptions regarding current and potential difference.

The student laboratory experiment for “Determining Charge on a Capacitor” (Appendix E) also addresses the changes in potential difference during charging and discharging. The mathematical derivation in the background of this experiment originates with Kirchoff’s loop rule and conservation of energy for the elements in the resistor-capacitor circuit.

Applications

A solid conceptual understanding of circuits in terms of conservation principles will set the stage for study of more complex circuits with capacitors. The ability to use circuitry becomes a tool for laboratory work not only in AP Physics B but also in subsequent work in science and engineering.

Formative Assessment

A sample formative assessment related to conservation of energy and conservation of charge in circuits is in Appendix F.

Activity 5: Conservation of energy in fluid flow

Common Misconceptions

Students tend to forget that the concepts for fluids apply to both liquids and gases. Also, Bernoulli’s equation is daunting for many students until it is related to the more familiar version of the work-energy theorem. Students seem to grasp its meaning when written:

$$P_1 + \rho gh_1 + \frac{1}{2} \rho v_1^2 = P_2 + \rho gh_2 + \frac{1}{2} \rho v_2^2$$

In this form, students are directed to compare these conditions at any two points in a moving fluid. The total remains constant. Then, to demonstrate the analogy further, remind students that this equation can be multiplied by the same quantity in every term on both sides. Multiplying every term by volume results in the following:

1. The pressure terms both become pressure multiplied by volume, which is work;
2. The ρgh terms both become gravitational potential energy terms, since density multiplied by volume equals mass; and
3. Both of the other terms become kinetic energy again, since density multiplied by volume equals mass.

In this way, students see it as more familiar in form and might more easily be able to work with Bernoulli's equation. Also, students need to be shown examples of such problems to gain practice in determining when certain terms on both sides can be cancelled, since they are virtually unchanged. An example is air moving over a curved airplane wing: the air pressure, ρgh , above and below the wing due to the depth of air is not significantly different for that small thickness of air in the atmosphere, so those terms can be cancelled from both sides. Now the equation looks much simpler, and students can take the next step to see that the difference in pressure, P , above and below the wing (causing lift) is due to the difference in the $\frac{1}{2}\rho v^2$ terms.

Teacher-Directed Activities

Examples of this concept can be demonstrated in class:

1. Use a large Styrofoam airplane to demonstrate Bernoulli's principle and lift. Purchase a small aluminum tube (about the size of a shortened pencil) and punch in through the side of the nose of the plane. Insert a long, thin metal rod through the tube so that the rod can be supported (on ring stands, for example). Now the plane should be able to rotate up and down on the rod. Use a leaf blower pointed at various angles toward the nose to show when the plane "lifts upward" from the table. Small streamers attached to the front edges of the wings also show laminar flow on the wing tops and turbulent flow just behind the wings when the plane has maximum lift.
2. Based on research that students can do on the size, weight, and lift forces needed for our largest commercial airplanes, a discussion of the "mechanics" of lift can provide an important context for the application of Bernoulli's equation.
3. Give each student a beaker of water and a straw. By blowing across the top of the straw, the student should produce increased speed of air across the top that results in reduced pressure. The water will rise in the straw — and the student will have created a "sprayer."

4. If there is access to an outside water faucet, attach a nozzle to a garden hose and spray straight upward. Using conservation of energy (Bernoulli's equation), an estimation of the height to which the water sprays can be used to calculate the speed of water as it exits the hose and the water pressure before the faucet is opened. (Note to students that this pressure is important to firefighters, who must be assured the pressure is adequate to spray to the top of a house on fire, in the event a "pumper" truck is not available.)

Applications

Bernoulli's equation helps to describe the differences in pressure caused by fluids flowing around objects such as airplane wings, building roofs during storms, boat sails, and golf balls. Students enjoy these discussions and will gladly bring in articles and research related to how boats can sail into the wind, how a spinning baseball can rise as it reaches the batter, and how a ski jumper can gain lift.

Activity 6: Photon Absorption and Emission

Concepts

Energy transfer occurs when photons are absorbed or emitted, for example by atoms or nuclei. Energy transitions for an electron correspond to the frequency (or wavelength) of photons emitted or absorbed during each of those transitions. An emission spectrum can be used to determine the elements in a source of light.

Misconceptions

Students are often confused by the frequency dependence (instead of intensity) of the current produced in the photoelectric effect. Units commonly used are electron-volts, which some students may still not identify correctly as energy units. Additionally, there will be some confusion about which value of Planck's constant to use in calculations.

Student Laboratory Activity

Power from a Solar Cell: Students define a scientific question, then design and conduct an experiment to research a problem related to solar cells. They are given a variety of light sources (e.g., flashlight, 60 watt bulb in a reflector), one or more solar cells (with electrical leads already attached), and electrical meters (ammeters and voltmeters). One possible research question might be: "How does distance from a light source affect the power produced from a solar cell?"

Depending upon the experience students have in developing their own experimental questions, the teacher may want to approve the scientific question as stated by the students prior to allowing them to proceed. The teacher may also want to "improve" the question by requiring that students develop a graph related to the question. Once the question is approved, students work in small groups, using the equipment provided and other necessary lab equipment (e.g., meter sticks, ring stands, electrical connectors), to design

and set up the apparatus. The entire experiment should be recorded in the laboratory journal. The teacher then will score the students' experiments based upon completeness of all requirements for a laboratory journal report and how well the experiment answers the question (see Appendix A).

Applications

Photocells (exposure meters in cameras) and solar cells are applications of the photoelectric effect; light strikes a metal surface, causing electron flow across a gap, completing the circuit. Light-emitting diodes emit light energy corresponding to the energy transitions for electrons in p-n type semiconductor junctions.

Alternative energy sources, such as solar cells, are an important topic that can be researched by students and integrated into this lesson.

Activity 7: Energy-Mass

Concept

Beyond the classical approximation, mass is actually part of the internal energy of an object or system with $E = mc^2$. The equation $\Delta E = \Delta mc^2$ can be used to calculate the mass equivalent for a given amount of energy transfer or an energy equivalent for a given amount of mass change (e.g., fission and fusion reactions).

Teacher-Directed Activities

The huge amount of energy produced in nuclear reactions (such as in a nuclear reactor or in stars) can best be exemplified for students by having them use $E = mc^2$ to convert a given amount of mass to energy. An example is the conversion of a deuterium nucleus, or deuteron, to a proton and neutron:



Using experimentally determined masses for each of these quantities, the student can be shown that the total mass of products (proton and neutron) is less than the original deuteron. This difference in mass, Δm , in atomic mass units, is used in the equation to determine the amount of energy released — over 2.2×10^6 eV. (Problem 7 on the 2001 AP Physics B Exam and Problem 5 on the 1991 AP Physics B Exam would be good examples to use as practice problems.)

Applications

An application of Einstein's famous equation occurs in nuclear processes, such as nuclear fusion and fission, in which the resulting mass defects appear as liberated energy. Another application of conservation of energy occurs in space exploration; for example, the Sojourner vehicle that drove on the surface of Mars was warmed by one-tenth of an ounce of plutonium-238 that released about 1 watt of thermal energy.

Summary

This section addressed the concept of conservation of energy in mechanical systems such as gravitational and oscillatory systems, thermodynamics processes, electrical circuits, fluids, and systems that involve the emission and absorption of photons. The underlying idea that the changes in potential, kinetic, and internal energies of a system are the result of the exchanges of energy in or out of a system is emphasized through the analysis of the properties of the system. Additionally, sign conventions for the calculation of work in various contexts in physics are outlined and clarified.

Conservation of Linear Momentum

Introduction

Linear momentum of a system remains constant if there is no net external force exerted on the system. Students learn first to identify the system under consideration and then to examine whether forces are internal to the system or external to the system in determining whether linear momentum is conserved. Additionally, the motion of the center of mass of the system remains constant unless a net external force is exerted on the system. Forces interacting within the definite system do not affect the linear momentum or center of mass motion.

The Concept

The linear momentum of a system is conserved.

Enduring Understandings

1. In an elastic collision between objects, both linear momentum and kinetic energy are conserved.
2. In an inelastic collision between objects, linear momentum is conserved, but kinetic energy is not conserved.
3. The velocity of the center of mass of the system cannot be changed by an interaction within the system. The center of mass of a system is described by the vector sum of the positions of each object in the system, weighted by mass. When two objects collide, the velocity of the center of mass of the system consisting of the two objects will not change.

Common Misconceptions

Students have difficulty with the terms *elastic*, *inelastic*, and *totally inelastic*. Few collisions on our everyday scale are elastic — implying no kinetic energy lost to thermal energy in the molecules of the colliding bodies. Examples that come closest are smooth, hard-surfaced bodies with little surface of contact on a frictionless surface (such as metal balls).

Even then, we hear the collision, meaning some energy from the system is converted to sound. Thus, most collisions we observe are at least partially inelastic. The term totally inelastic means that the colliding bodies stick to each other during the collision and are considered one object after the collision.

Another common misuse of kinetic energy in collision problems is in finding how much the kinetic energy changed during the collision. In this application, the change in kinetic energy should always be calculated as: $\Delta K = K_f - K_o$

When the total kinetic energy of objects after the collision is less than total energy before the collision, the change in kinetic energy will be negative — not indicating a direction, as one might use with a vector, but indicating that kinetic energy is “lost” to the system (or transferred in some other form, such as sound).

Students have some difficulty with the vector nature of momentum. They must be reminded that velocities in opposite directions must be given opposite signs to indicate their directions. In any situation in which the collision does not have the centers of mass of the colliding bodies along a line or is not “head on,” the motions of the bodies after the collision will be in two dimensions, so the velocity or momentum vectors must be split into components. On the other hand, kinetic energy is scalar, so kinetic energy is not split into components. The word “collision” has a specific meaning to most people, such as one car colliding with another. However, in the context of this concept in physics, a collision is an interaction between two objects or systems where forces are exerted over a finite period of time, such as the collision of the aforementioned cars, a baseball player catching a ball, or the interaction of two protons in the Large Hadron Collider.

Instructional Activities

Teacher-Directed Activities

Open this discussion by showing students many examples of colliding objects, such as:

1. Collide steel balls or marbles on a straight, grooved track (or use a Newton’s cradle) to simulate elastic collisions. Remind students that by setting up the collisions horizontally on a level surface, the gravitational force does not intervene, thus linear momentum is conserved. Ask for evidence that the collisions are not elastic (e.g., sound energy). Try rolling 1, 2, 3, etc., at a time into a lineup to see the same number leave after the collision. Then roll two from opposite directions at the same speed and at different speeds to demonstrate that momentum is conserved.

- Using two smooth balls or coins of the same mass on an open surface (e.g., bowling balls on the floor or nickels on a desk top), set one object as a stationary “target.” Roll or slide the second one into the first enough times to demonstrate both “head-on” and “off-center” collisions. (See the “Nickel Collisions” lab in Appendix G.)

Student Laboratory Work

“Low-Friction Cart Collisions” (See Appendix H)

“Ballistic Pendulum” (See Appendix I)

Classroom Activities

There are many sample AP Exam problems related to conservation of linear momentum that can be used for in-class practice (e.g., Problem 1 on the 1990 AP Physics B Exam or Problem 7 on the 2002 AP Physics B Exam). Given two or three free-response problems, students work in groups of two or three to solve problems while the teacher circulates through the classroom to check student progress and answer brief questions or provide hints. In this way, the teacher can get direct feedback regarding the types of questions student have and where difficulties lie before a summative test over the unit. Students who do not yet have a solid understanding of concepts can learn from other students with whom they work in the small groups.

Applications

Particle collisions in a nuclear research facility, such as Fermilab or the Large Hadron Collider, yield information for physicists regarding the properties of the colliding particles and their by-products through the application of conservation of energy and conservation of momentum principles (as well as other, less familiar, conservation principles).

Summary

This section presented the conservation of linear momentum in a system isolated from external forces. The activities focused on mechanical systems, but the application of this concept to particle collisions highlights the fact that conservation of momentum applies to all scales, including subatomic particles.

Conservation of Angular Momentum (for Physics C: Mechanics)

Introduction

The moment of inertia of an object or system depends upon the distribution of mass within the object or system. Changes in the radius of a system or in the distribution of mass within the system result in changes in the system's moment of inertia and, hence, in its angular velocity and linear speed for a given angular momentum. Students should be able to apply angular momentum concepts to elliptical orbits in an Earth-satellite system. However, the emphasis is conceptual.

Concept

The angular momentum of a system is conserved.

Enduring Understandings

1. If the net external torque acting on the system is zero, the angular momentum of the system does not change.
2. The angular momentum of a system is determined by the locations and velocities of the objects that compose the system.

Common Misconceptions

Students may confuse angular momentum with circular motion. The distinction needs to be clarified with illustrative examples of situations in which the distribution of mass is altered to increase angular speed, such as the rotation rate of a spinning ice skater or of a diver.

Instructional Activities

Teacher-Directed Activities

1. To demonstrate conservation of angular momentum, a student sits on a rotating stool (or stands on a rotating disk) with a workout weight in each hand. (Safety note: Select the type of weights with handles so the student can hold them securely.) As the student sits, well balanced, on the stool with hands, weights, and legs extended, start the student's rotation. On a signal, ask the student to quickly "tuck" (i.e., bring arms and legs in). (Safety note: Stand near the student as a "spotter" — ready to step in if the student tips off balance and begins to fall.) Students should observe and be able to explain that as the student tucks, rotational inertia decreases so angular velocity increases, conserving angular momentum.
2. Demonstrate how the constructions of two objects with the same mass and size can change moment of inertia. Use two PVC pipes about $\frac{1}{2}$ inch or $\frac{3}{4}$ inch in diameter with end caps for each end of both. Locate four "cement anchors" or heavy bolts that just barely slide into the pipes, and keep a snug fit in the pipes. Put two anchors into each pipe, located near the ends in one pipe and near the center for the other pipe. Replace the end caps so the two objects now have the same size and same mass but different internal structures. Ask for two student volunteers, have each volunteer hold a pipe at the middle, and have them "race" in the effort to rotate the pipes back and forth at the fastest rate. Of course, the rod with the anchors on the ends has higher momentum of inertia and is much more difficult to start moving.
3. Use either a commercially purchased bicycle wheel demonstrator or an old bicycle wheel as a visual aid to discuss the parameters of rotational motion. A small, soft ball with a cut in it mounts on a spoke and makes a reference for rotation.

Student Laboratory Work

Appendix J contains ideas for experiments related to conservation of angular momentum and conservation of energy in a linear-rotational system in the lab "Rotational Kinetic Energy."

Applications

Kepler's Laws of planetary motion use this concept to describe how planetary bodies in elliptical orbits (including the Earth-Moon orbit around the Sun and each planet's orbit about the Sun) change speed in the orbit as the orbital radius changes. As the Earth, for example, approaches its perihelion (point closest to the Sun), its orbital radius decreases and orbital speed increases, conserving angular momentum.

In sports such as diving and skating, the performer can change angular velocity by "tucking," or quickly changing the person's effective radius (and changing moment of inertia). Students who have experience with skating or doing flips can report to others how important the quick change in moments of inertia is to the sport.

Summary

This section covered the conservation of angular momentum as it applies to mechanical systems and elliptical orbits in an Earth-satellite system. The section includes activities that allow for group work on the direct measurement of angular velocity and moments of inertia.

Conservation of Mass

Introduction

Within this section, students will learn to apply mass conservation or mass-energy conservation in several contexts. The continuity equation for fluids, for example, is presented here from the basic concept — that as long as the density of the fluid does not change, the mass rate of flow must remain constant as the cross-sectional area of flow changes, resulting in changes in velocity. Students can certainly relate this to common observations. In a quite different context, students will be introduced to mass conservation in nuclear reactions, which should be linked to the energy conservation section to develop the concept of mass-energy conservation and also linked to the following unit on conservation of charge as it applies to nuclear reactions.

Concept

Classically, the mass of a system is conserved.

Enduring Understandings

1. Classically, the mass of a system is conserved.
2. The continuity equation describes conservation of mass flow rate in fluids.

Instructional Activities

Activity 1: Continuity of fluid flow

The rate at which a mass of fluid passes a given point along the flow each second (e.g., kg/s) must remain constant. Present the example of water flowing through a garden hose. As you put your finger over the end of the hose to constrict the flow — reducing the cross-sectional area — you know from experience that the water will speed up, increasing its flow rate. If we assume the water is not compressible and does not change its density, we can examine the following equation: $\rho A_1 v_1 = \rho A_2 v_2$

In the equation, apply units to each of the quantities to prove that the units on each side of the equation are kilograms per second. Canceling the density term from each side — since it is the same — produces what is commonly known as the “fluid continuity equation”: $A_1v_1 = A_2v_2$

Teacher-Directed Activities

Most science rooms have a tapered nozzle attached to laboratory faucets. The water flowing through the nozzle moves with much greater speed as it enters the region of the nozzle that has smaller cross-sectional area. (Students can relate to having had a piece of equipment knocked out of their hands in the sink when such a faucet is turned on too quickly.)

1. The tapered nozzle attachment on a leaf blower demonstrates the principle. Bring one into class and compare how far above the blower a plastic ball will hover with and without the attachment.
2. Students already know that the water flows faster out of a garden hose when they put a thumb over the end or attach a nozzle.

Applications

The nozzle on a garden hose reduces the cross-sectional area of flow so that the velocity of water leaving the hose nozzle increases, increasing the impulse at point of contact and striking surfaces with greater force. A fire hose is a practical case, where increasing the water speed allows the water to travel higher in the air.

Gasoline does not burn in automobile engines, but gasoline vapor will burn. When fuel is pumped from a larger tube to a smaller tube in the carburetion system, the rate of fluid flow increases, as stated in the fluid continuity equation, conserving mass rate of flow. This increase in flow rate also results in a reduction in pressure (see the discussion of Bernoulli’s equation under conservation of energy), resulting in vaporization of the fuel, so that it is ready to mix with air and send on to the cylinders.

Development of the concept of conservation of mass in fluid flow will help students relate somewhat to conservation of charge during current flow in electrical circuits. Though the mechanisms are not the same, analogies are often drawn between the two to help beginning students develop a conceptual understanding of current.

Activity 2: Balancing nuclear equations

Concept

In a nuclear equation, total mass and energy before and after the reaction should be the same.

Classroom Practice

Use sample nuclear equations during class to familiarize students with nuclear fission and fusion and with the types of particles involved. This is an opportunity, for example, to

research the chain of nuclear reactions on the sun. Similar equations can then be used for group or individual assessments to determine student understanding. Some examples of nuclear reactions that might be included for classroom assessment or practice include:

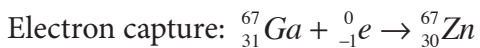
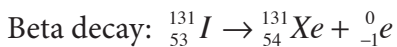
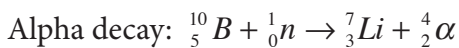

Applications

Research physicists, such as those at Fermilab or the Large Hadron Collider, examine the paths of particles that are products of collisions or nuclear reactions — as recorded by detectors — to discover and determine the masses of particles produced in particle collisions.

Summary

This section summarized related conservation of mass concepts with recommended classroom activities, examples for classroom practice, and applications. The section focused on the continuity equation as it describes the conservation of mass flow rate and the study of conservation of mass in nuclear reactions.

Conservation of Charge

Introduction

This lesson offers an analysis of the conservation of charge in electrical circuits focusing on the application of Kirchhoff's junction rule, followed by a conceptual explanation of the conservation of charge that applies to systems that exchange charges.

Concept

The electric charge of a system is conserved.

Enduring Understandings

1. Electric charge is conserved in nuclear and particle reactions, even when particles are produced or destroyed.
2. The exchange of charges among a set of objects in a system conserves electric charge.
3. Kirchhoff's junction rule describes the conservation of electric charge in electrical circuits.

Instructional Activities

Activity 1: Charge conservation in electrical circuits

Kirchhoff's junction rule describes the conservation of electric charge in electrical circuits. Since charge is conserved, current must be conserved at each junction in the circuit. Likewise, the current flowing into and out of a circuit element is the same. The energy of the charges may be used to produce light, for example, but the charges themselves are intact.

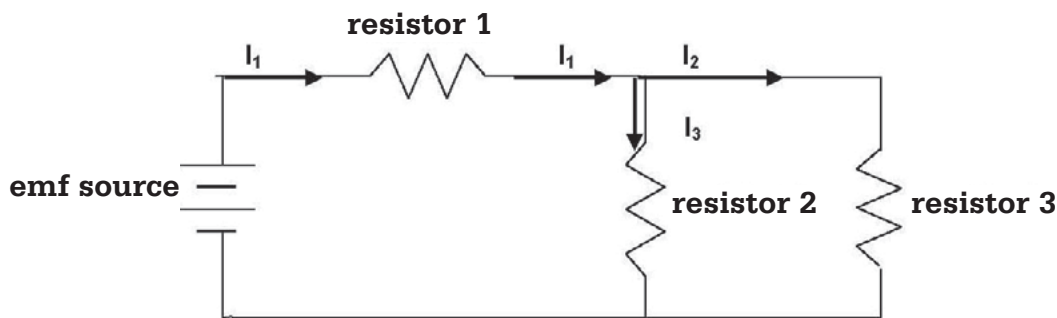

Figure 10

Common Misconceptions and Adjustments

Students just beginning the study of circuits commonly hold the belief that charge is “used” by components (e.g., that a lightbulb gives off light because, somehow, the current is “used up” by the bulb). Shown a circuit with two lightbulbs of different wattage in series, students will often respond that the brighter bulb “uses up” the current, leaving less current for the bulb that is less bright. Careful examination of such circuits — along with a clear demonstration and explanation — is important to dispel this common misunderstanding. (See “Determining Wattage” teacher demonstration in Appendix C.)

Other difficulties that will be addressed in this section are students’ lack of understanding of (a) how a voltmeter and an ammeter should be used to make measurements; (b) the meaning of power in lightbulbs (i.e., the belief that a bulb always dissipates the amount of power stated in its label); and (c) how to model actual circuits with schematic diagrams.

Some students believe that changing the order of components in a series circuit will somehow change the current in or potential difference across these components. Teacher demonstrations in which the order of connections can be manipulated and discussed (such as the “Determining Wattage” demo) and student labs in which students make observations and measurements in circuits for different configurations will help to dispel this belief.

In AP Physics B, the fundamental elements of electrical circuits are introduced using conservation of energy and conservation of charge concepts without an in-depth study of electric fields and potentials. It is important to use extensive examples and demonstrations so that beginning students develop a clear understanding of how circuits actually operate. This understanding becomes more conceptual with the addition of the study of electric fields, potential, potential energy, and potential difference.

Students have difficulty with the operation of ammeters and voltmeters and their correct use and connection in circuits. The translation of schematic diagrams to the construction of actual circuits (with meters and without “short connections”) is an additional common

difficulty. The teacher should observe carefully as students set up and perform the activities in student lab “Introduction to Electrical Circuits” (Appendix D) to make sure meters are connected properly. Students’ diagrams of their setup, drawn as schematics in their laboratory journals, can also be used to assess student understanding of how to use meters and draw schematic diagrams from actual circuits. If this understanding does not seem clear, the teacher can devise a “circuit lab checklist,” where each student in turn demonstrates these proficiencies with their group and each group member signs off on the individual’s ability to use meters and set up circuits.

Teaching Activities

The following activities all include large group or small group work, including methods of assessment:

1. Teacher Activity: Determining Wattage (Appendix C)
2. Student Laboratory Activity: Introduction to Electrical Circuits (Appendix D)
3. Student Laboratory Activity: Determining the Charge on a Capacitor (Appendix E)
4. Formative Assessment: A Circuit with a Diode (Appendix F)

Formative Assessments

1. The teacher may collect and read the laboratory journal analysis of the circuit activity, watching for misstatements, erroneous conclusions, and incorrectly drawn circuit diagrams.
2. During the teacher demonstration of “Determining Wattage,” getting students involved in a dialogue as each step is taken during the demonstration will bring out both correct and incorrect conclusions from observations. Sample questions with answers are provided with the demonstration directions in Appendix C.
3. Select a released AP Physics free-response problem that involves decision making about the constructions of circuits, calculations of current in circuits, and connections of ammeters in circuits (e.g., Problem 4 on the 1996 AP Physics B Exam). Assign students to work in small groups on the solution, giving them about 20 minutes to hand in a “group” paper.
4. The formative assessment in Appendix F provokes thinking about current direction and charge flow.

Reflections

In this lesson, the concept of conservation of charge in electrical circuits was taught and reinforced through a variety of learning activities that addressed the common misconceptions and difficulties students have with electrical current. Some choices in methods of approach to each activity provide the teacher with differentiated instructional

techniques to recognize the range of skills and learning styles students also bring with them. Student laboratory activities, along with development of the laboratory journal, offer students several ways to express their thoughts in written, artistic, mathematic, and graphical formats. Student group work in the class and in the laboratory provides students with peer-learning opportunities. Teacher-directed activities with accompanying interactive dialogue with students allow students the options to learn through careful listening and observation or verbal interaction. And formative assessments described in the lesson allow the teacher to repeat, adjust, reteach, or create new methods of presentation in response to students' needs.

A basic knowledge of circuits developed through conservation concepts — perhaps introduced early in the year or in a preparatory course — is important for the successful understanding of more advanced circuits later in the year or in a subsequent course. Electrical circuits are also important tools in laboratory in all the sciences, such as electrochemical cells in chemistry and electrophoresis in biology.

Knowledge of electricity and circuits is important for understanding technological developments requiring action and/or decisions by the public. As gains are made in solar cell technology or the operation of an electric car, students as adults can make better decisions regarding their own use or public policy changes.

Activity 2: Balancing nuclear equations

Teacher-Directed Activities

Students need practice balancing nuclear equations at the direction of the teacher and familiarization with common radiation products such as alpha, beta, and gamma. The same set of equations used previously as applied to conservation of mass can now be reexamined in terms of conservation of charge, this time focusing on the numbers along the bottom on both sides of each equation:

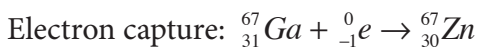
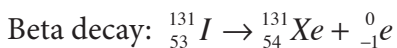
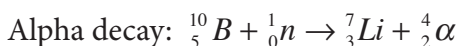

Applications

Students will be able to apply these concepts in their study of chemistry, where nuclear equations are also commonly studied. Knowledge of the properties of nuclear radiations and the mechanism of damage to human cells is applicable to biology.

Knowledge of nuclear reactions and particles is important for the understanding of nuclear energy power sources — risks, limitations, and potential for future use and development of public policy.

With the start-up of the Large Hadron Collider, an understanding of charges and charge conservation helps in understanding the processes and some of the experiments that have been designed to study particle collisions.

Activity 3: Charge Separation

Concepts

The exchange of charges among a set of objects in a system conserves electric charge. Charging by conduction between objects in a system conserves the electric charge of the entire system. Grounding involves the transfer of excess charge to another system (e.g., the Earth). Charge separation in a neutral system can be induced by an external charged object placed close to the neutral system.

Teacher-Directed Activities

Various combinations of objects can be used to demonstrate separation of charge to students, prompting questions that reinforce concepts and allowing the teacher to assess students' understanding. The teacher might demonstrate the example in Figure 10 and then allow students to practice a few examples on their own from an assortment of materials provided.

1. In the demonstration, the large, inverted watch glass provides a nonconductive base on which to balance the meter stick. An ebonite rod can be charged negatively by contact with a piece of fur or wool. Bringing the charged rod near one end of the stick induces a positive charge on that end. Then move the rod slowly away from the stick. The force of attraction will produce a torque on the stick, causing it to rotate. To test for understanding, ask questions such as:
 - a. What is the induced charge of the other end of the stick? (negative)
 - b. What is the net charge on the meter stick when the charged rod is near it? (zero)
 - c. What is the charge of each end of the stick and the net charge on the stick when the charged rod is removed? (zero in all cases)
 - d. What will be the charge on the meter stick if the charged rod is touched to it? (negative)

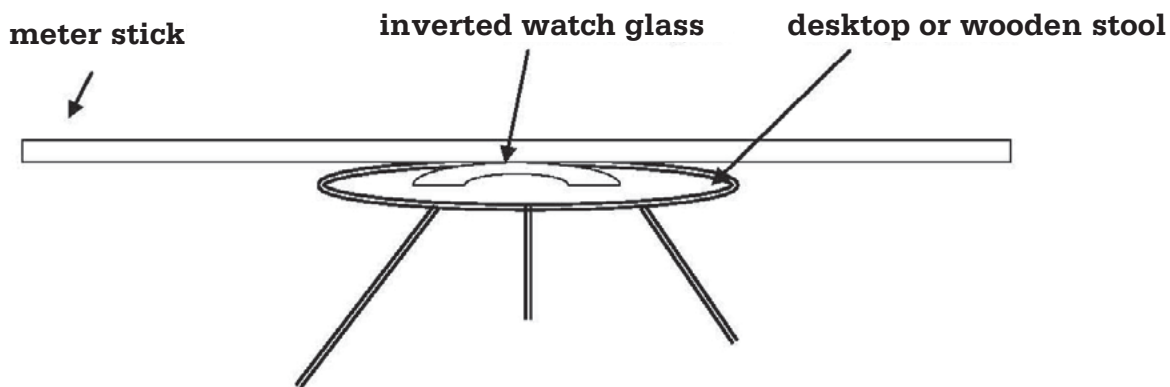

Figure 11

2. A banana hanging from a thread will perform in the same way as the meter stick above but makes a slightly more interesting demonstration.
3. Give students materials such as a plastic comb, pieces of wool, and small pieces of Styrofoam to try this effect for themselves.

Applications

A working knowledge of charge separation and conservation of charge will be helpful in later study of electrical discharges. Lightning is an interesting example of charge transfer from one object to another to build large electric potential difference.

Capacitors are common in everyday applications — flash devices in cameras, timing circuits in computers, and automatic electric defibrillators now available in public spaces as life-saving devices.

Summary

This section offered an analysis of the conservation of charge in electrical circuits, focusing on the application of Kirchhoff's junction rule, followed by a conceptual explanation of the conservation of charge that applies to systems that exchange charges. The third part of the lesson focused on the analysis of conservation of charges that occur in radioactive decay. The demonstrations provided can be linked with earlier topics on electric forces, electric fields, and torque. A lesson in the next section, Appendix C, on "Determining Wattage," provides more specific types of activities that might be used to present the concept of charge conservation in electrical circuits and address students' misconceptions.

References

College Board. AP Physics Commission materials prepared during the AP Physics Redesign project collated by the College Board, 2007.

College Board. Algebra-Based Physics Curriculum and Cognitive Frameworks. Physics Curriculum Development and Assessment Committee. Report of AP Physics Redesign prepared by the College Board, 2008.

Giancoli, Douglas C. *Physics: Principles with Applications*. 6th ed. Upper Saddle River, NJ: Prentice Hall, 2006.

Haber-Schaim, Uri, and John H. Dodge. *Potential Energy of a Spring*. Lab experiment from PSSC Physics Teacher Workshop. Colorado School of Mines, 1989.

Halliday, David, Robert Resnick, and Jearl Walker. *Fundamentals of Physics*. 8th ed. Danvers, MA: John Wiley & Sons, Inc., 2008.

Serway, Raymond A., Jerry S. Faughn, and Clement J. Moses. *College Physics*. 6th ed. Pacific Grove, CA: Brooks/Cole, 2002.

Serway, Raymond A., Jerry S. Faughn, and Chris Vuille. *College Physics*. 7th ed. Belmont, CA: Thomson Brooks/Cole, 2006.

Walker, James S. *Physics*. 3rd and 4th editions. Upper Saddle River, NJ: Pearson/Prentice Hall, 2007.

Additional Resources

Conner, Donna B. *A Potpourri of Physics Teaching Ideas*. College Park, MD: AAPT, 1987. [Another excellent source of demos for beginning teachers; available from AAPT]

Bueche, Frederick, and Eugene Hecht. *College Physics: Schaum's Outline Series*. 10th ed. New York: McGraw-Hill, 2005. [An excellent review book or source of supplemental problems]

Cutnell, John D., and Kenneth W. Johnson. *Physics*. Hoboken, NJ: Wiley, 2009. [Excellent ancillary materials, particularly tests]

Edge, Ronald. *String and Sticky Tape Experiments*. College Park, MD: AAPT, 1989. [Available from AAPT; excellent source of easy, inexpensive demonstrations; a “must” for beginning teachers]

Ehrlich, Robert. *Turning the World Inside Out*. Princeton, NJ: Princeton University Press, 1990. [Available on AAPT website; excellent source of inexpensive, effect demonstrations]

Gautreau, Ronald, and William Savin. *Schaum's Outline: Theory and Problems of Modern Physics: Series*. 2nd ed. New York: McGraw-Hill, 1999. [Available in college bookstores; good summary of modern physics topics]

Haber-Schaim, Uri, John H. Dodge, Robert Gardner, Edward A. Shore, and Felicie Walter. *PSSC Physics*. 7th ed. Dubuque, IA: Kendall/Hunt, 1991. [Excellent resource for laboratory experiments and inspiration]

Hewitt, Paul. *Conceptual Physics*. Boston: Addison Wesley, 2010. [A “must read” for new teachers; good reference text that explains physics in everyday terms]

Serway, Raymond A, Robert J. Beichner, and John W. Jewett. *Physics for Scientists and Engineers*. Fort Worth, TX: Saunders Publishing, 2000. [A good reference text to use for Physics C and good reference for Physics B teachers, particularly on electricity and magnetism; recommended resource for background on advanced topics such as capacitance]

The Physics Teacher (magazine and online). [Excellent source of information and ideas regarding laboratory work; subscription with membership to American Association of Physics Teachers]

Additionally, check <http://www.apcentral.collegeboard.com> for extensive teacher resources and access to released AP Exams for use as practice for students.

Appendix A

Laboratory Report Format

To the Student

All lab reporting should be done directly in the lab notebook. Prepare as much as possible prior to the actual lab day (Parts 1 through 4 below and necessary tables). In the upper-right-hand corner of the first page, write your name, the date, and the names of your lab partners or collaborators.

1. Give the lab a **title**. (Creativity is appreciated, but a subtitle should be more descriptive of the procedure.)
2. State the **problem** or **purpose**.
3. List **materials** used and provide a brief description or diagram of the **setup**.
4. Provide essential **background** information to be used during the experiment: important formulas, constants, procedural cautions for safety or error reduction, etc.
5. Gather **data** and record in a form clearly and quickly discerned by the reader. A data table can be the most concise way to do this (include units on all measurements). Construct **graphs** whenever feasible, making them half-page or full-page so that values can be determined accurately. Include all other **observations** or **adjustments** that may be important in developing the analysis later. Show **calculations** clearly, with formulas and correct units substituted.
6. The **analysis** should be your own unique work (similar to an English paper). The analysis should be in complete, self-inclusive sentences, should be written as soon as possible after the experiment is performed, and should include:
 - Estimates of uncertainty associated with any measurement;
 - Calculation of **percentage error**, where applicable;
 - Discussion of **sources of error** and possible methods of reducing those errors;
 - Answers to “targeted” questions set forth by the teacher in complete, self-inclusive sentences (i.e., no need to write out the question and answer, but a reader should be able to know what the question was when reading the answer);
 - Conclusions from **analysis of data and graphs**;
 - **Suggestions for improvement** of experimental design;

- **Predictions** of experimental results under different conditions; and
- **Extrapolations** (i.e., other experiments or a modification of this experiment that might better answer the question or answer a related scientific question).

To the Teacher

Laboratory work is developed to illustrate and reinforce concepts, apply mathematical and graphing skills, and help students develop analytical skills. Teachers may assess students’ work in the laboratory journal to help both teacher and student reflect on concepts and their practical applications to reveal deeper understanding. All student laboratory experiments and teacher-directed activities that involve the class in measurements should be recorded by students directly in the laboratory journal. Students should then be assigned to prepare the Analysis section (with answers to targeted questions) as work outside of class.

This laboratory journal design is a suggested routine used by this author for laboratory record-keeping — a set of standards not specifically recommended or required by the College Board. However, it is highly recommended that AP Physics students keep a permanent record of all laboratory work in a bound format for the teacher to evaluate students’ understanding and provide feedback. It is recommended for the teacher to develop a rubric to score the journals that assign point values and allow space for teacher comments. A sample scoring rubric might look like this:

Charging a Capacitor	(points possible)	(points earned)
Title and purpose clearly stated	2	
Background with all relevant information, formulas, and derivations	3	
Labeled diagram of setup	3	
Data table with units	2	
Observations	3	
Calculations clearly shown	3	
Accurate graphs (title, axes labeled, units, best fit curves, equation)	8	
Quality of analysis	6	
Total	30	
Comments:		

Laboratory work is an opportunity for students to reinforce concepts; apply their knowledge; and demonstrate their creative, analytical, and mathematical skills. The teacher can foster these skills and improve the quality of the laboratory journal record in several ways:

1. Allow students increasing freedom in laboratory design as their skills develop.
2. Require higher-level analytical techniques, such as multiple graphs with calculated slopes and areas to determine experimental quantities.
3. Provide “targeted questions” for students to incorporate into the analysis. These questions should provoke deeper analytical thinking about the experimental problem. (Some examples are provided with the student laboratory activities in the Appendixes.)
4. Require students to consider other experimental questions that might be investigated with the same equipment or other quantities that could be derived from the experimental data.

Appendix B

Student Lab: Ball on a Ramp

(Recommended time: one class period)

Purpose

Use potential and kinetic energy calculations of a ball on a ramp to determine the speed of the ball as it leaves the ramp, and use that speed to predict the position where the ball will land on the floor. An estimation of work done against friction should be included.

Use the range of the ball to determine a value for coefficient of rolling kinetic friction between the ball and ramp, including both translational and rotational motion of the ball.

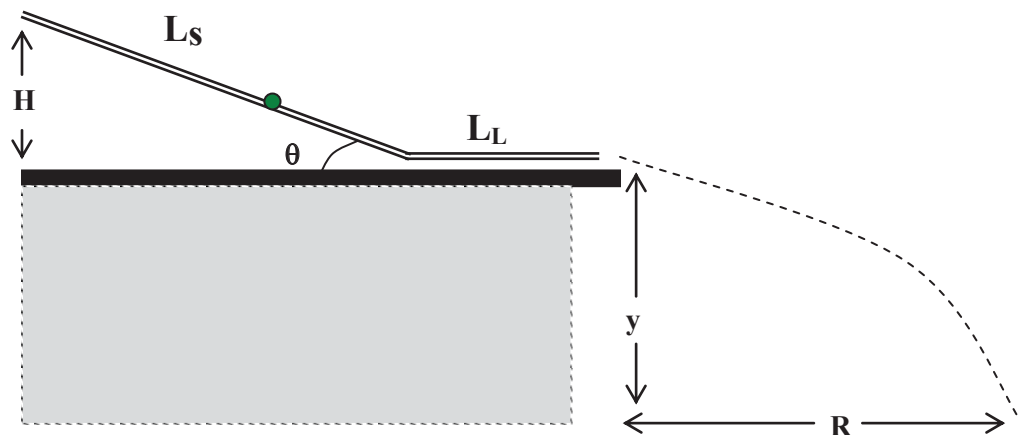

Figure 12

Teacher Notes

Leave as much of the design of the experiment as possible to students. They may either be given ramps constructed of curved aluminum door track from the hardware store or design their own ramps from pieces of wood, meter sticks, clamps, etc.

- To avoid trial and error methods, students should not be allowed to let the ball hit the floor until they have calculated the landing point.
- Provide carbon paper to use (face down) at the site to mark the landing point on the floor.

- When calculating the energy “lost” to work against friction, do that calculation in three steps: (1) calculate the work against friction on the sloped part of the ramp; (2) calculate the work against friction on the level part of the ramp; (3) add the two.
- Estimate a coefficient of rolling friction of about 0.02.
- The equations students should derive:

$$\Delta PE + \Delta KE_{(translational)} + \Delta KE_{(rotational)} = W_f$$

$$mgH = (F_f)(L_s)_{slope} + (F_f)(L_L)_{level} + \frac{1}{2}mv^2 + \frac{1}{2}I\omega^2$$

$$mgH = (\mu mg \cos \theta L_s) + (\mu mg L_L) + \frac{1}{2}mv^2 + \frac{1}{2}\left(\frac{2}{5}mr^2\right)\left(\frac{v}{r}\right)^2$$

$$mgH = (\mu mg \cos \theta L_s) + (\mu mg L_L) + 0.7mv^2$$

Journal Analysis Questions

- What method of determining the velocity was the most accurate?
- What might be another method of determining the ball’s velocity as it leaves the ramp?
- What are some possible sources of error in your measurements?
- Physics 1: How did neglecting the rotation of the ball affect your results?
- What ultimately happens to the energy that is given up to “work done against friction”?
- What ultimately happens to the energy of the ball when it hits the floor?
- How could energy conservation principles be used to find the vertical velocity gained by the ball in its trip from the end of the ramp to the floor?

Assessment

Students will record all observations, data, calculations, and responses to analysis questions in the laboratory journal. The teacher can then determine what misconceptions or difficulties with calculations students may have by examining the journal. The students’ ability to participate in the design of the experiment has important ramifications to development of scientific reasoning and inquiry skills. The teacher should encourage and reward alternative approaches to the experimental design.

Appendix C

Teacher-Directed Activity: Determining Wattage

This is a teacher-directed activity derived from one presented by Chuck Britton in the Woodrow Wilson Institute held at Benedictine College in 1991. The activity demonstrates and reinforces important concepts in electric potential difference, current, resistance, and power for series and parallel circuits. It is designed specifically to address students' misconceptions regarding current in circuits and what is meant by electrical power. Feedback from students is essential to the purpose of this demonstration, which usually requires a full 45-to 50-minute class period. This can be accomplished in several ways:

1. For small classes, ask for student responses to each step of the demonstration — and move about the class asking for variations on those responses before accepting and confirming the correct response. (However, make sure students feel “safe” with this method, i.e., “no wrong answers” — just answers that contribute to the final accepted answer.)
2. Have students write their observations, draw schematics, and do calculations in their lab journals as the teacher demonstrates, and then have them write an analysis that summarizes what they learned as homework.
3. For larger classes, a “clicker” response system, where students answer questions posed by the teacher during the demonstration by pressing a button, would be effective in determining student responses.

Equipment

Purchase clear bulbs such as might be used in home lighting — one each of different wattage and shape (e.g., a clear 25W tapered bulb and a clear 20W ceiling-fan bulb). Clear bulbs allow students to see the filaments, and low wattages keep temperatures lower.

For the first part of the experiment, two small lamps can be plugged into a power strip (without shades); these will be in parallel. Two other lamps or sockets should be carefully rewired so they are in series and then connected to a power strip for safe operation.

Demonstration

1. With the switch off, plug the 25W and the 40W bulbs into the parallel outlets and turn on the switch. Have students record observations as it is turned on and off and as each bulb is removed and replaced. Demonstrate that the bulbs operate independently and that the brightness of one bulb is not affected when the second bulb is added or removed.

2. With the switch off, move the 25W and the 40W bulbs to the lamps connected in series and turn on the switch. Again, have students record observations as the bulbs light, the appearances of the bulbs when on, and the effects of removing and replacing each bulb — both in its original position and then switching positions.
3. Show students how to calculate the operating wattages of both bulbs when they are plugged in series. (Sample calculations are shown below.)
4. Have students draw schematic diagrams of each type of connection.
(Note: We are neglecting in the discussion here that the electrical source is AC and we are treating it as if it were effectively a DC circuit — which makes little difference in the concepts being reinforced by this demonstration.)
5. Note that the bulbs were originally marked “25W, 120V” and “40W, 120V” — reinforcing the idea that they operate at given wattage only at required voltage.

Questions to ask students

- In which situation do both bulbs have the same current in them?
[Answer: In series.]
- How does changing the order of the bulbs wired in series change their brightness?
[Answer: It doesn't.]
- In which situation do both bulbs have the same potential difference across them?
[Answer: In parallel, such as in your home.]
- What is the effect in the parallel circuit of disconnecting one bulb? [Answer: No effect.]
- In the parallel circuit, what is the effect on a burning bulb when the second bulb is plugged in? [Answer: No effect.]
- In the series circuit, what is the effect of removing one bulb? [Answer: The other does not light; the circuit is incomplete.]
- In the series circuit, what is observed if the bulbs switch positions? [Answer: No effect. The same current goes through each, regardless of order. It's important to clarify this here, because students often have the misconception that the “first” bulb in the series circuit “uses up” the current.]
- What happens to the comparative wattages of the bulbs when switched from the parallel circuit to the series circuit? [Answer: The higher wattage bulb is less bright.]
- Which bulb has the higher resistance? [Answer: The bulb marked with higher wattage has less resistance.]

- What is the effect on the currents in each bulb when they are connected in series and in parallel? [Answer: In parallel, each bulb receives more current, because the total resistance of the bulbs is lower in parallel and the current in the circuit is higher. Even though the current splits into the parallel branches, the current in each bulb is still higher.]

Sample Calculations of Wattage

In order to do this, the assumption must be made that the resistance of each bulb remains constant throughout the demonstration. In fact, the bulbs receive more current in the parallel circuit, so the filaments become hotter. The filament resistances become greater when the bulbs are hotter, since the resistivity (ρ) of the filament material increases with temperature. This should be pointed out to students. It might also be an opportunity to explain why lightbulbs tend to burn out as they are switched on: cold filament, cold filament resistance, lower resistance, a surge of current that causes rapid expansion of the filament ... and breakage of a weak filament.

$$R = \frac{\rho L}{A}$$

1. First, do the calculations of bulb resistances in the parallel circuit, where the operating wattages are as marked.

a. **25-watt bulb:**

$$P = 25W$$

$$V = 120V$$

$$P = \frac{V^2}{R}$$

$$R = 576\Omega$$

b. **40-watt bulb:**

$$P = 40W$$

$$V = 120V$$

$$R = 360\Omega$$

2. Assuming these resistance values stay the same, determine the wattages of the two bulbs when connected in series.
 - a. Total resistance of the two bulbs in series: $R_T = R_1 + R_2 = 936\Omega$
 - b. Voltage across both the bulbs is 120 V for this circuit.
 - c. Calculate the current in the circuit: $I = 0.128A$ (same in both bulbs).
 - d. Calculate the power, or wattage of each bulb:

(i) **bulb marked “25-watts”:** $P = I^2 R = (0.128 A)^2 (576 \Omega) = 9.4 W$

(ii) **bulb marked “40-watts”:** $P = I^2 R = (0.128 A)^2 (360 \Omega) = 5.9 W$

Assessment

Students should be able to calculate wattage, current, voltage, and resistance for a simple circuit with given values. Once the values are provided, allow students to work in small groups to determine the wattages of the bulbs when connected in series. Walk through the class to check whether students are able to do this. If they are not successful, it may be necessary to review the last steps of the process and/or prompt with equations and suggestions until students are able to produce correct answers.

Students should also be able to provide short answers to questions similar to those provided above on a short “quiz” or other formative assessment given immediately following this lesson. Question 4 on the 1998 AP Physics B Released Exam would be an excellent assessment of students’ ability to connect a circuit and answer questions about the brightness of bulbs in various orientations in the circuit.

Reflection

This is an important demonstration in which the teacher can present the basic concepts of circuits in a visual way that appeals to many students’ learning styles. Students will remember how the bulbs behave if the teacher emphasizes clearly how the connections are made and reinforces the concepts with schematic diagrams on the board. The lesson also provides the opportunity to connect to practical applications by discussing how these concepts apply to what students use in their homes.

Summary

Students should be prepared by this teacher-guided exercise to complete the student lab “Introduction to Electrical Circuits” in Appendix D and demonstrate what they have learned.

Appendix D

Student Lab: Introduction to Electrical Circuits

(Recommended time: two class periods)

Purpose

Measure voltage, current, and resistance in electrical circuits and determine whether the behavior of these circuits is “ohmic.”

Background

- The equation that relates voltage (V), current (I), and resistance (R), is Ohm’s Law:
 $V = IR$
- Voltage is measured in volts (v), current is measured in amps (A), and resistance is measured in ohms (Ω).
- **For safety, always connect the electrical power supply through the circuit breaker, and don’t turn on the switch until all connections are made and everyone is clear of the connections.**
- To avoid burning out bulbs unnecessarily, increase the voltage on the power supply only enough to see clearly how the bulbs light.
- To check that your circuit is in **series**, you should be able to track one single path of current flow through every element in the circuit. To check that your circuit is wired in **parallel**, you should be able to find where the current has to split and branch in order to flow through every element in the circuit.
- Total resistance for elements connected in **series**: $R_t = R_1 + R_2 + R_3 \dots$
- Total resistance for elements connected in **parallel**: $\frac{1}{R_p} = \frac{1}{R_1} + \frac{1}{R_2} + \frac{1}{R_3} \dots$

Directions

1. Select two lightbulbs.
2. Measure the cold resistance of each.
3. Connect **one** bulb to the power supply, turn up the voltage until it glows.
4. Measure the current in the circuit and the voltage across the bulb.

5. Repeat Steps 3 and 4 for two more power supply settings, making sure not to set the voltage so high that it burns out the bulb.
6. Graph *Voltage vs. Current* and attach to the lab journal. Determine whether the slope comes close to the measured resistance of the bulb (i.e., whether or not the bulb is “ohmic”).
7. Connect two bulbs in series and repeat Steps 4 and 5, comparing the measured voltage across the two bulbs to the calculated voltage for the two bulbs.
8. Connect the two bulbs in parallel and repeat Step 7.
9. Draw labeled schematic diagrams for each of your circuits in your laboratory journal.

Sample schematic diagram for two resistors (bulbs, in this case) wired in series:

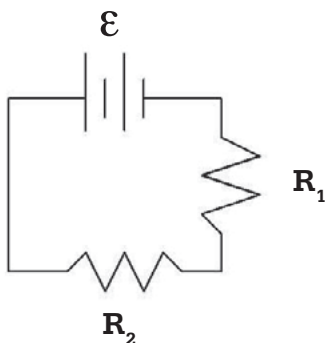

Figure 13

Analysis Questions

Include your responses to these questions as self-contained paragraphs in your analysis, along with conclusions related to your observations of the circuits and calculations of the slope of the graph.

- If two bulbs are connected in series, how would it change the brightness of the bulbs (if no other changes in the circuit are made) if the order of the bulbs in the circuit is switched?
- If two bulbs are connected in parallel, how would it change the brightness of one bulb if the second bulb is disconnected?
- How closely does the total of the voltmeter readings for all the bulbs in series match the voltmeter reading for the connections across the output (power supply or battery or generator)? What causes the difference?
- Why might it be important to check the resistance of the lightbulb when it is still warm?

- What are the units on the slope of the *Voltage vs. Current* graph?
- Show that these units are equivalent to the units on resistance.

[Credit for the demonstration goes to Chuck Britton, Woodrow Wilson Physics Workshop, Benedictine College, Atchison, Kan., 1991.]

Teacher Notes: Introduction to Electrical Circuits

This laboratory activity is designed to give students practical experience with series and parallel circuits so they can observe the behavior of lightbulbs in series and in parallel. They also gain experience in making electrical connections and using ammeters and voltmeters to make measurements in a circuit. Students should be encouraged to group themselves so they can work at a rate appropriate to their skill level to encourage a more investigative approach by students who are less experienced with circuits.

Equipment and Setup

There are several alternative ways in which this experiment can be set up for students, depending upon available materials and budget:

1. Small flashlight bulbs with bases available at hardware stores and commercial variable voltage DC power supply;
2. Christmas tree lights cut from the strand and 9-volt batteries;
3. Light-emitting diodes and hand-crank generators (like the Genecon), or some variation of these, connected with alligator clip wiring; or
4. Light-emitting diodes and resistors connected using a plug-in type experimenter breadboard.

Digital multimeters are recommended (and available at large hardware or electronic supply stores), as they are easier for beginning students to use and aren't as easily damaged by reversed connections.

Instructional Plan

Prior to the lab, students should be introduced to Ohm's Law, and the parameters of voltage, current, and resistance should be defined, along with the symbols and units for each. Advance instruction should include drawing some simple series and parallel circuits on the board and working problems with students to show them how to analyze the circuits using conservation of charge and conservation of energy principles. (Refer to the sections titled Conservation of Energy, Conservation of Charge, and Teaching Lesson: Conservation of Charge.)

Prior to the activity, students should be instructed on the correct use of voltmeters and ammeters, and they should be provided with safety warnings appropriate to the equipment being used.

Adjustments

Read the “Common Misconceptions” in the Conservation of Charge and Conservation of Energy sections and decide how these misunderstandings will be addressed. It is recommended that the Teacher-Directed Activity, “Determining Wattage,” be performed prior to this activity to address the misconceptions directly, avoiding frustration by students in this lab when they try to apply concepts. If light-emitting diodes are used, warn students that they must connect a “current-limiting” resistor in series with each diode to protect it from burning out, and that diodes only allow current in one direction (so the direction of connection is important for LEDs but is not important for small bulbs and resistors).

This lab activity is helpful for students of varying abilities to extend the range of their experiences. Within their small groups, students should be encouraged to take turns making the connections — with the approval of others in the group — so that each student gains “hands-on” experience. Those groups that work faster could be encouraged to set up more complicated series-parallel circuits.

Assessment

Students record all data, observations, schematic diagrams, and graphs in the laboratory journal (see Appendix A). In this particular student lab, it is important to provide students with immediate feedback, either by walking through the class and checking student work directly or by collecting the journals to check and return quickly before the students proceed with other parts of the lesson. Another option is to create a “circuit checklist” and have other students use the checklist to sign off on basic skills, such as: (1) schematic diagrams correctly drawn; (2) meters connected correctly; (3) correct units on all measurements; and (4) graphs set up with correct axes and correctly calculated slope.

The same parameters listed above should be considered by the teacher in evaluating students’ work in the laboratory journal, as well as all the other elements of a good experimental write-up, as outlined in Appendix A. The students’ analyses should also contain appropriate observations related to the circuits, conclusions related to the graphical interpretation, and correct answers to the “targeted questions.” Students’ journals should be scored on the basis of quality of observations rather than the extent to which they may have experimented with complicated configurations.

Reflection

The appeal and greatest benefit of this lab to students is the opportunity they are given to set up various circuit configurations in a way that is not stressful or intimidating to them. Students of varying abilities are given the opportunity to work at their own rates.

They are given ample time to experiment with various types of connections and to make observations about their results.

Summary

In this student-led activity, students design and set up circuits to investigate and observe for themselves how modifications in circuits affect how elements of the circuits behave. Conservation of charge and energy in circuits should be easier for students to understand when related to observations.

Appendix E

Student Lab: Determining the Charge on a Capacitor

(Recommended time: two class periods)

Purpose

Determine the charge on a capacitor after charging by examining data from charging and discharging and finding the value of the capacitance.

General Method

- Construct graphs of current (I), voltage across resistor (V_r), and voltage on capacitor (V_c) as functions of time for charging and discharging.
- Calculate the charge on the capacitor by finding the area under I vs. t graphs.
- From the charged capacitor voltage and charge, calculate capacitance: $Q = CV$
- Use the capacitance and maximum charging voltage to calculate stored energy:

$$U = \frac{1}{2}CV^2$$

Background

Students record pertinent information from class presentation prior to this lab in their laboratory journals.

Charging

The entire experiment needs to be done on a nonconducting surface, such as cardboard, to make sure discharging doesn't take place on the surface.

Schematic for charging circuit:

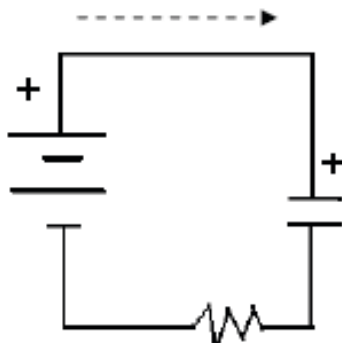

Figure 14

1. Find a resistor that is a suitable size, based upon time constant (approximately 100 k Ω charges a 2200 μ F capacitor in 7–8 minutes), to slow down the charging and discharging processes:

$$\tau = RC \text{ (time for 62 percent of charge on exponential curve)}$$

2. Make sure the voltage supplied is within the range marked on the capacitor.
3. Connect the capacitor in series with the resistor, as marked on the package. (Note: Attempting to charge an electrolytic capacitor with the poles reversed can damage the capacitor or cause it to overheat and explode.)
4. Do a trial run on the circuit with a voltmeter to check the power supply voltage. Record this value and keep it constant.
5. Discharge the capacitor completely by holding a conductor (e.g., a screwdriver with an insulated handle) across the capacitor leads.
6. Connect a voltmeter across the resistor.
7. Immediately upon closing the charging circuit, start recording the voltage across the resistor every 10 seconds until the voltage readings level off (i.e., the same reading 3 times in a row).
8. Careful: You now have a charged capacitor!
9. Quickly disconnect the circuit.

Discharging (Optional)

1. Without allowing any discharge of the capacitor, immediately remove the power supply to connect only the charged capacitor and the resistor in series.
2. Leave the voltmeter connected across the resistor.

3. Immediately upon closing this circuit, start recording the voltage across the resistor every 10 seconds until the voltage readings level off.

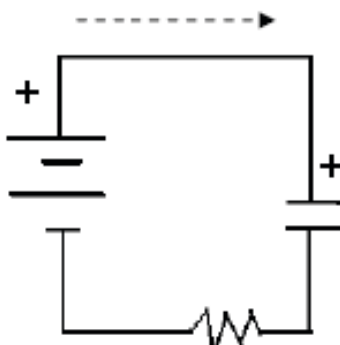

Figure 15

Analysis Recommendations

To determine current values to make the I vs. t plots, use the voltage values and the known resistance for the resistor. (Remember: The only current is through the resistor; no current flows through the capacitor.) To find the voltage values for the charging and discharging capacitor, remember Kirchhoff's loop rule: The total voltage change throughout any circuit adds to zero. Thus, the sum of the voltages of the resistor and the capacitor equals the power supply voltage at any given time.

After plotting I vs. t for charging and discharging, determine the charge (for both charging and discharging), using one or both of the following methods:

- Draw a "best fit" line onto the I vs. t graph that approximates the area by including about the same amount of extra area above the curve as it omits below the curve. Then determine the area, which will be the charge.
- Integrate the equation for the *Current vs. Time* graph, then substitute a value to time when you stopped charging. Use your values for charge and voltage to calculate a value for capacitance; compare this to the marked value on the capacitor.

Use the equation $Q = CV$ to determine a value for capacitance, and the equation

$$U = \frac{1}{2}CV^2 \text{ to calculate stored energy.}$$

Analysis Questions

- Why does the current switch directions for the charging of the capacitor and discharging?
- Explain why the area under the *Current vs. Time* graph from $t = 0$ to the charging time is the total charge on the capacitor for that amount of charging time.
- What would be the effect on the energy stored in the capacitor if the charging voltage were doubled? Explain your answer.
- What are some practical uses for capacitors? Why are they particularly useful for these applications?

Teacher Notes

This lab is necessarily “prescriptive,” as it is often a difficult one for students and teachers. Careful background planning, derivation of equations (appropriate to the level of the class), and descriptions of the method will help make the process less intimidating — and safer. The discharging cycle is optional; it is simply a demonstration to students and a “check” on the charging data.

Students should understand the structure and function of capacitors prior to performing the experiment. The teacher should derive the equations that describe charging of capacitors using conservation concepts and show students qualitatively the shapes of the curves that describe current and potential difference for both charging and discharging. Though students will not be required to derive those equations or perform calculations for time-varying circuits as part of the AP Physics B course, they should recognize the shapes of the curves and have an understanding that the potential difference on the capacitor during charging increases exponentially and approaches the charging voltage asymptotically.

Student laboratory notebooks (see Appendix A) should contain:

1. Background showing the circuit equation with Kirchhoff’s loop rule as a starting point in the derivation;
2. Conservation of charge statements describing the amount of charge on the capacitor as a function of the current and time;
3. Clearly organized data table;
4. Accurately prepared graphs of *Current vs. Time*, *Potential Difference vs. Time Across the Resistor*, and *Potential Difference vs. Time Across the Capacitor*;
5. Calculations clearly shown for the charge on the capacitor, capacitance value, and energy stored on the capacitor; and
6. Thorough, insightful analysis that includes responses to the “targeted questions.”

Sample Results for Capacitor Lab

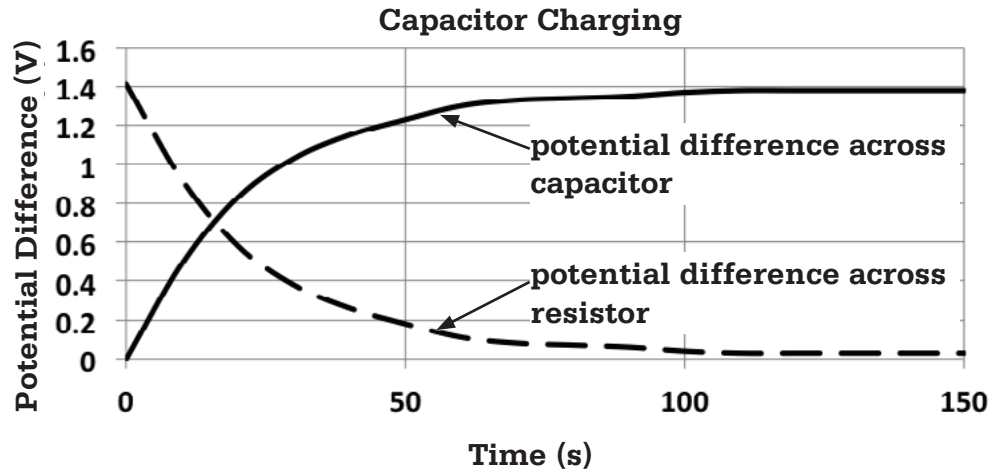

Figure 16

To calculate capacitance from data (t , V_r , V_c , I):

1. Find the maximum charge accumulated on the capacitor by finding the area under the *Current vs. Time* curve, by one of the following methods:
 - a. Integrating the equation for the I vs. t graph;
 - b. Photocopying the graph onto quadrille paper, finding the value of each square, and counting squares;
 - c. Drawing a “best fit” line over the I vs. t curve that includes about the same amount of extra space as it excludes, and finding the area of the triangle.
2. Use the maximum charging voltage (the asymptote of the V vs. t charging graph) and the charge obtained from area of the I vs. t graph: $C = \frac{Q}{V}$
3. Calculate stored energy using $\frac{1}{2}CV^2$.

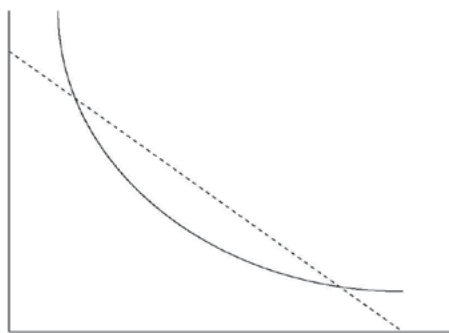

Figure 17

Assessment

Problem 2 on the 2003 published AP Physics B Examination (http://apcentral.collegeboard.com/apc/public/repository/ap03_fig_physics_b_23086.pdf) provides a similar question that would help the teacher assess student understanding of determination of charge on a capacitor.

The teacher should evaluate students by observation, checking in frequently with each working group and asking questions to test their understanding and to determine if they have questions. More formally, the teacher's evaluation of the laboratory journal will provide feedback to students regarding errors in schematic circuit drawings or calculations and misconceptions revealed by the written analysis.

Reflection

Students will be challenged by this lab, but they will gain a greater understanding of an asymptotic charge rate by watching the slow change in meter readings as the charge accumulates on the capacitor. The graphical methods for processing data involve higher order analytical skills appropriate for the latter half of the course. The most capable students will relish the challenge of an attempt at using their calculus to find the capacitor charge, and the alternate methods of determining the charge make an excellent result attainable for less capable students.

Summary

Conservation of charge and conservation of energy are the concepts most directly reinforced by this lab. However, in their study of the concept of electric field, students can relate to their observations here. The experiment involves a combination of scientific inquiry skills (including graphical analysis methods), mathematical calculations, and interpreting observations and data in order to answer the targeted questions.

Appendix F

Analysis of a Circuit with a Diode

Formative Assessment

(Recommended time: 30 minutes)

Formative assessment is a teaching tool that provides for purposeful interactions between teacher and students. As students progress through assigned tasks, the teacher can diagnose and respond. After students have been given an opportunity to work together on an activity, the teacher joins the student group and asks pivotal, thought-provoking questions that have been prepared in advance. In turn, students make their thinking visible to the teacher. The types of communication in the feedback process can vary. Responses may be oral or written or involve a sequence of instructional activities, and the teacher should reflect on the efficacy of the approach with respect to different learning styles, preferences, and interests. Each formative assessment should provide a sequence of increasingly higher order cognitive demands. Success is achieved when both teacher and student are satisfied that the learning objectives of the task have been met.

Instructional experiences defined by the teacher are directed toward a set of enduring understandings defined by the AP Program. To connect the curriculum to the AP Exam, the formative assessment is based on standards of student performance selected from the set of expectations that define the AP Exam. Each formative assessment is situated within a scenario that reflects the set of enduring understandings (content) and skills. The scenario may be situated within emerging areas of research or contexts that engage student interest. The tasks are intended to target common misperceptions that hinder a student's understanding of a concept.

Released AP Exams often serve teachers and students as a way of preparing for the exam. Students can use released exam questions to calibrate their performance and to become familiar with the format and expectations of exam items. Instructors need to use released exams to infer the scope of appropriate content. Formative assessments recognize this and offer an alternative tool that is designed to support learning rather than evaluation.

Teacher Notes

It is the expectation that students can approach the analysis of a circuit as an application of the principles of energy and charge conservation. Students and instructors often approach circuit analysis as the application of a set of rules that are disconnected from the conservation principles that they express. Without a rational foundation for these rules, some students find them difficult to learn, retain, and apply. This formative

assessment presents a scenario involving a circuit with a device that is probably not considered in this course and challenges the students to apply principles of energy and charge conservation to the analysis of a diode.

The context for this formative assessment — the diode — is a component of the integrated circuits in the student's cell phone, MP3 player, and computer. The physics of the p-n junction that lies at the heart of this component is beyond the scope of this course. However, the tasks provided are not intended to assess students' understanding of the physics of doped semiconductors. The purpose is to provide a situation in which the ability to use the understanding contained in the learning objective in a novel, engaging context can be assessed.

The discussion in the tasks presented to students introduces the means by which regions with higher and lower densities of valence electrons are established by introducing impurities to a silicon crystal. A drawing is used that exaggerates the densities of impurities by many orders of magnitude. No discussion of energy bands is presented; current is described in terms of the displacement of valence electrons from the region of higher density in the direction of higher potential. The construction of knowledge by analogy to more familiar situations is supported, and students may be able to compare this concept to an object sliding down a hill. No discussion of the displacement of holes in the direction of lower potential is attempted. However, a grasp of the concept of conventional current will be revealed.

The mathematical representation of the relationship between the current and the applied voltage provides a challenge to explore the dependence of a simple function on sign. It is not necessary to introduce language such as *forward-biased*. It might be useful in a whole class discussion to consider how the diode provides a gate that opens and closes according to the value of V in that equation and how gates can be used to represent logical processes.

The final task challenges students to develop a strategy for the analysis of a circuit involving a diode. Difficulties in this task may point to the absence of a useful connection between conservation principles and Kirchhoff's rules. If in subsequent work the student studies RC and LR circuits, then the approach they may develop here will be revisited. The ability to propose a strategy that is conditional and must be tested is often difficult, and the teacher might observe a connection to current direction at a junction. Remember that the focus in this assessment is not on p-n junctions but conservation principles.

Interested students might be directed to the computer simulation of diode circuits developed by Dean Zollman and his students at Kansas State University:
web.phys.ksu.edu/papers/sds/SDSPaper.htm

Student Assessment

The integrated circuits in your cell phone, MP3 player, and computer have many components made from materials called semiconductors. These materials have

conductivities that are between those of conductors and insulators. The conductivity of the material can be altered by changing the electrical or thermal properties of the environment or by changing the chemical composition of the material. In particular, conductivity can be controlled by the addition of impurities, called dopants, to the crystal lattice of a semiconductor.

The dopants can either act as electron donors to produce what is called an *n-type semiconductor* or as electron acceptors (sometimes called “holes”) to produce a *p-type semiconductor*. Silicon atoms have four electrons that are at higher energy states, often referred to as valence electrons. A boron atom has only three valence electrons. So boron atoms introduced as impurities in a silicon lattice can act as electron acceptors. Phosphorus atoms have five valence electrons and so can act as electron donors.

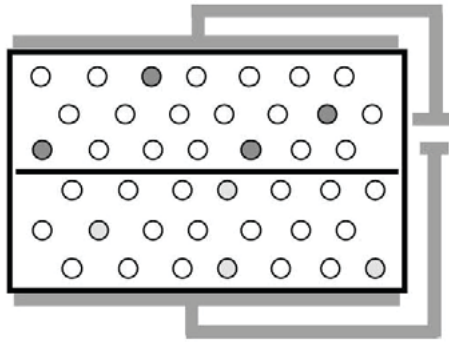

Figure 18

When a p-type semiconductor is in contact with an n-type semiconductor, the relative tendency to donate or accept electrons produces an electrical potential difference across the interface between the two materials, called the *p-n junction*. By connecting this junction to an external circuit and applying an external potential across the junction, current can be induced.

Work with your group and discuss your answers to the following questions, then record your answers in your lab notebook.

1. In the diagram above, the darkest shaded spheres are boron atoms, the lighter shaded spheres are phosphorus atoms, and the white spheres are silicon atoms. Sketch the diagram in your lab notebook. Use a solid arrow on your sketch to show the direction of conventional current flow. Justify your answers using the properties of the dopant atom. Is the current composed of positive or negative charge carriers?

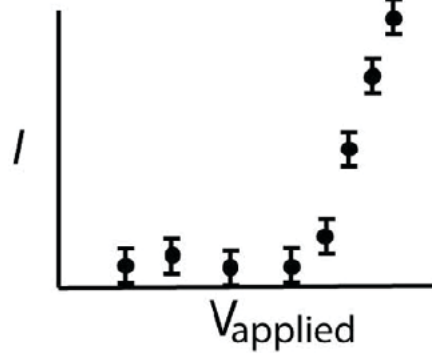

Figure 19

2. The figure above shows the relationship between measurements of current (I) connected across the p-n junction as a function of the applied electric potential difference (V). Add to the sketch in your lab notebook the way in which the ammeter and voltmeter should be connected to obtain the readings.
3. Describe the pattern that you see in this dependence of current on applied electric potential difference. Consider this current, in terms of rate of charge flow, as a function of electric potential difference, and in terms of electric potential energy per charge. Describe a comparison of what happens in this circuit to the gravitational potential energy of an object at different heights above the Earth.
4. The mathematical representation of the relationship between current and applied electric potential difference across a p-n junction is given by this equation: $I = I_{\text{sat}}[e^{cV} - 1]$ where I_{sat} has a very small positive value and c is a positive constant that depends on the properties of the semiconductors. Describe how this equation behaves when the applied potential V changes sign. Is this equation consistent with your data? If so, what does that tell you about I_{sat} ?

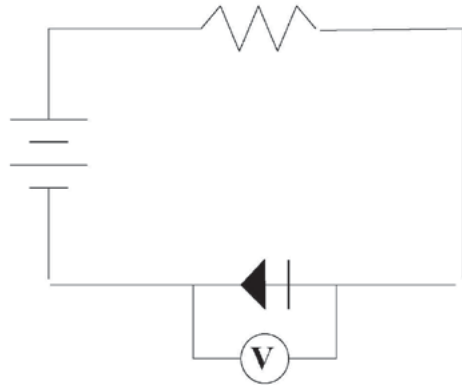

Figure 20

5. The circuit above contains a semiconductor device called a diode, indicated by the triangle. Ignore that component for the moment and write down the relationship between current (I), resistance (R), and electric potential difference (V) in the circuit without the diode. What principles were used to write this relationship?
6. Suppose now that the diode is connected as shown. Work out a strategy for writing the relationship between current and potential for the circuit with the diode by applying the same principles used in your answer to part 5 and your understanding of the behavior of a current across a p-n junction as a function of the properties of the applied potential. Justify any assumptions that you make and describe what you would do to test your assumptions.
7. Now the circuit is reconstructed with the diode connection switched so that the diode is drawn in the opposite direction. What would be your answers to the previous questions (from #6)?

Interpretive Framework

In answering the questions on the formative assessment, it is anticipated that students will be challenged to explain the direction of conventional current flow in the circuit in terms of the direction of electron movement at the p-n junction. They may also have lingering questions about how to connect the ammeter and voltmeter to obtain the necessary readings. Some students implement the idea of positive charge carriers as thinking of the direction of an electron current and then reversing it. In the first task, using the idea of conventional current in a new setting might create a challenge for some students. The direction of the arrow in the lab notebook sketch might be wrong, but they might also have it done correctly without conceptual understanding. It might be useful to ask the small group a question about how a “hole” could be a useful idea for describing current in a semiconductor.

As students work, the teacher can quickly discern whether students are having these difficulties by examining the diagrams students produce in the laboratory journal. Once the diagrams are correct (i.e., conventional current flow from the high potential side of the power source, represented by the longer bar on the diagram, to the low potential side and electron flow through the diode in the opposite direction), students have the right idea. If students have difficulty with the explanation, encourage them to reread the information provided prior to the questions.

If, from their diagrams, students appear to have meters connected incorrectly in the circuit to make measurements for the diode, they may need to be reminded of the purpose of each of the meters: an ammeter to measure current and a voltmeter to measure potential difference. Provide a hint for those students and allow them to consider it further: For the ammeter to measure the current, the ammeter must be connected so the current flows through it. The voltmeter must measure the potential difference across the diode. It is hoped that this is enough for students to conclude that the ammeter must be connected in series — on either side of the diode — and the voltmeter must be connected in parallel, with a connection on each side of the diode.

An analogy for the third task might be a book that slides when the incline is sufficiently steep or sand on a dune. They might not see that the steep rise in the function corresponds to the onset of a current. A good question would be what happens if the battery is connected with the positive pole on the n-type side of the junction.

In parts 5 and 6, they should write down their strategy as a set of rules, and if they haven't, then they could be asked to express the strategy so that anyone with no physics training could use this set of rules.

Some algebra-based physics students might not yet have learned about logarithms and exponential functions. To keep them from stopping at this point in the sequence, suggest that it is just a number e raised to a positive power cV and ask what such a function would do as the power became more positive. For example, if $V = 0$, then $cV = 0$ and e^0

is 1. The expression inside brackets is zero, so $I = 0$. If cV increases to 2, then $e^2 = 7.4$ and the value of I becomes 7.4 times I_{sat} . The current increases exponentially as V gets more positive. They can then get to the more important point: If I_{sat} is very small and V is negative, the current is very small in the other direction, so the diode acts as a “one-way gate” for current.

Appendix G

Student Lab: Nickel Collisions

(Recommended time: one class period)

Purpose

To compare both head-on and nonhead-on elastic collisions between objects of equal mass and objects of unequal mass.

Method

Part I: Using one nickel as a stationary target, gather information about the subsequent paths of the nickels for both head-on and nonhead-on collisions. Present the data as measurements and as tracings or diagrams.

Part II: Repeat Part I, this time using two nickels that are not exactly of equal mass.

Data Analysis

- Make all relevant conclusions, using averages of the measured readings.
- Show the mathematical derivation of velocities v_1 and v_2 after the nonhead-on elastic collision between two nickels of equal mass.
- Include labeled vector diagrams of all trials.

Analysis Questions

- What measures did you take to make sure the nickels' masses were the same?
- What measures did you take to decrease the effects of friction between the surfaces?
- Do you think it would make a difference in the experiment if the nickels were heads up or heads down? (Try it if you're not sure.)
- If the collisions are not perfectly elastic, how do the equations used in calculations change?
- If the masses are not the same, how do the equations used in calculations change?
- If the collisions are not perfectly elastic, what happens to the "lost" kinetic energy after the collisions?

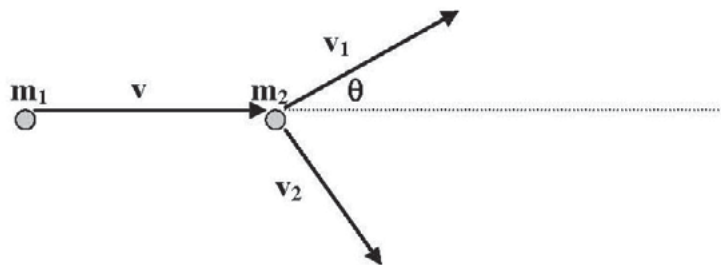

Figure 21

Equation 1: x-direction : $mv = mv_1 \cos \theta + mv_2 \cos \varphi$ (conservation of momentum)

Equation 2: y-direction : $mv = mv_1 \sin \theta + mv_2 \sin \varphi$ (conservation of momentum)

Equation 3: $\frac{1}{2}mv^2 = \frac{1}{2}mv_1^2 + \frac{1}{2}mv_2^2$ (conservation of KE - elastic collisions)

[Note: Basically, you are proving that a right angle forms, by showing that $\varphi + \theta = 90^\circ$]

Advanced Experiment

This same method can be applied to the design of a more complex quantitative problem in three dimensions. Set the target nickel on the edge of a desk and shoot the second nickel so that the nickels fall onto the floor. Students measure the ranges and angles for the nickels to determine the resulting velocity vectors, and then calculate the velocity of the nickel prior to the collision.

Teacher Notes

Students will learn to “shoot” the second nickel either by flipping with their fingers or sliding it down a small ramp.

Assessment

Students will record all observations, data, vector diagrams, and calculations in the laboratory journal. The equations shown above should be shown with a clear explanation or proof of why the collisions are elastic (i.e., why students get close to 90 degree exit angles for the nickels after the collisions). By reading the analyses, the teacher can determine whether students understand the concepts and are able to justify the use of the above equations. A clear understanding of linear momentum is necessary background knowledge for concepts related to conservation of angular momentum, which is studied later.

Reflection

The simplicity of this activity allows students to focus on the basic concepts related to elastic collisions. Students should understand the requirements for the assumption of conservation of kinetic energy in the collision of two coins, i.e., that: (a) the coins are of equal mass, (b) the surface is effectively frictionless, and (c) nickels are used because they have smooth edges to reduce interaction at collision. The related mathematical proof is important to students' understanding of this special case — and why the resultant paths of the coins are at a 90-degree angle for an off-center collision.

Summary

This activity to demonstrate elastic collisions between objects of the same mass costs little or nothing, can be performed by students within one class period, and effectively demonstrates both conservation of kinetic energy and conservation of linear momentum.

Appendix H

Student Lab: Low-Friction Cart Collisions

(Recommended time: one class period)

Equipment

Low-friction table, two low-friction carts, two motion sensors

Purpose

Determine the changes in kinetic energy during a collision between two carts on a low-friction cart/table apparatus and compare the linear momentum before and after the collision.

Directions

1. Use motion sensors to gather data on the motions of the carts before and after collisions.
2. Analyze the data graphically and print the graphs.
3. Use the data to calculate the total momentum of the two carts before the collision and after the collision.
4. Use the data to calculate the change in total kinetic energy of the carts for each collision.
5. Analyze the data and graphs in terms of the stated purpose.

Recommended Journal Analysis Questions

- Why is the sign on the velocities in your calculations important?
- Discuss a different experiment that could be performed with the same equipment.
- How closely do the calculations for linear momentum before and after the collision agree?
- What are some possible factors that affected the outcome of your experiment, and how could the effects of these factors be reduced in future trials?

Teacher Notes

- The conservation principles applied on this lab will be applied in later units on conservation of angular momentum and in the discussion of particles collisions in AP Physics B.
- Allow students to discuss in groups how the data will be gathered and what steps will be taken to reduce experimental error (e.g., making sure the track is level, taking data from multiple trials).

Assessment

- Encourage students to restate the purpose in terms of whether or not they will assume the collisions to be elastic. They will then decide whether to compare final momentum to original momentum and calculate percentage error or calculate the difference in total final and total original momentum to determine the change in momentum.
- Students will record all data and observations in the laboratory journal (see Appendix A). The teacher can determine and respond to errors in calculations or conceptual misunderstandings after reading students' analyses.

Reflection

This laboratory activity gives students the opportunity to observe firsthand the energy and momentum changes during collisions as they observe the motion sensor graphs. If the graphing program can be set to “real-time” mode, these changes become even more evident to students. Students should be able to conclude that kinetic energy may not be conserved in situations where momentum is conserved by using computer-generated data to make the appropriate calculations. Students should be able to discuss any “loss” of kinetic energy in terms of gain in thermal energy of molecules of the apparatus and air around the apparatus (including the sound of the collision).

Summary

In this student-led activity, students design and set up an experiment to test conservation of kinetic energy and linear momentum during a collision. The data are gathered using motion sensors interfaced with a computer (or calculator, as an option) so that students can express their results graphically and verify them with calculations.

Appendix I

Student Lab: Ballistic Pendulum

(Recommended time: one class period)

Purpose

- a. To use the concepts of conservation of angular momentum and conservation of energy to derive a formula for velocity of the ball leaving the projectile launcher.
- b. To make appropriate measurements to solve for the velocity.
- c. To test the launch velocity by launching the ball horizontally from a height and measuring the range on the floor.

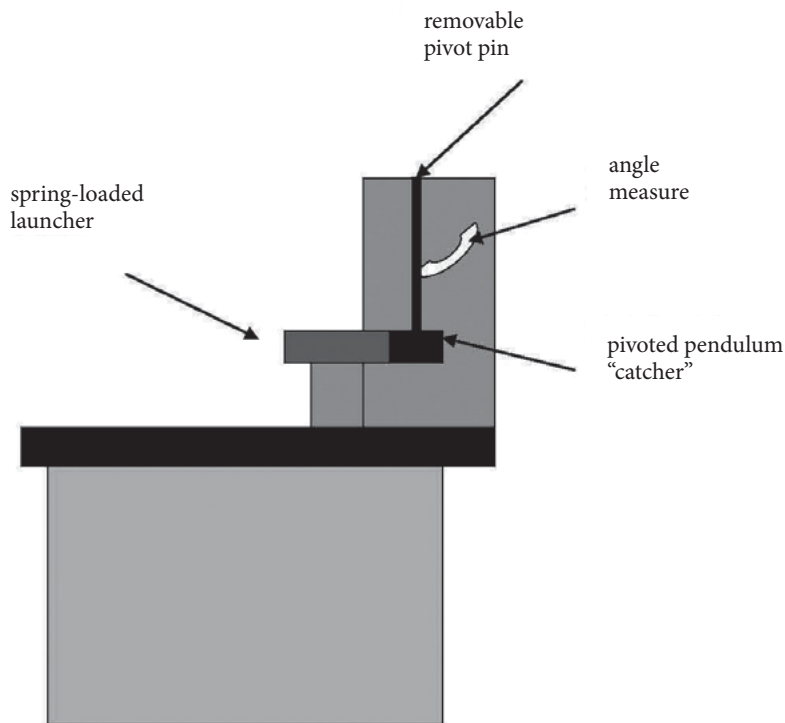

Figure 22

Background

The concept underlying this experiment is conservation of linear momentum at the time of impact. The ball fired by the launcher is assumed to have the same angular momentum as if it were on a thin string swinging like a pendulum into the catcher ($I = mr^2$). The catcher (with ball) has angular momentum after the inelastic collision and is treated like a compound pendulum with moment of inertia I_p (below). Conservation of mechanical energy is then used to determine the angular velocity of the catcher after the collision in terms of the gravitational potential energy at the highest point in its swing. The following “master formulas” will be derived in class and should be entered into the journal:

$$I_p = \frac{MgR_{cm} T^2}{4\pi^2}$$

$$v_b = \frac{1}{2} \sqrt{2MgI_p R_{cm} (1 - \cos \theta)}$$

M = mass of pendulum (with ball)

R_{cm} = distance from pivot to center of mass of pendulum

r_b = distance from pivot to center of mass of ball when fired

θ = angle of displacement of pendulum after firing

I_p = moment of inertia of pendulum with ball

T = period of oscillation of ballistic pendulum with ball

Remove the pendulum catcher and fire the ball horizontally to test the launch velocity of the launcher, measuring the range and using projectile motion equations to solve for the ball's velocity. While the pendulum is removed, balance it carefully on a loop of string to find its center of mass. Measure the distance from the pivot point to the center of mass, R_{cm} . Reset the pendulum but remove the launcher and allow the pendulum to swing freely (with the ball in the catcher) to determine the period of the pendulum's oscillation. Use multiple trials.

Recommended Analysis Questions

- What are some other methods that might be used to check the launch speed of the ball?
- How will the results (moment of inertia, velocity of ball, range of ball, angle) vary if a plastic ball of the same size but different density is used?
- What measurement likely produced the largest source of error? How would an error (high or low) affect the experimentally determined launch speed of the ball?

Teacher Notes

This commercial ballistic pendulum consists of a spring-loaded launcher that fires a small steel ball into a catching device that can pivot like a pendulum. After the ball is fired and caught by the pendulum/catcher, the pendulum with the ball in it swings upward, carrying a marker that can measure the angle. Conservation of angular momentum can be used to calculate the speed of the ball as it leaves the launcher. (Note: In the absence of this equipment, the teacher could set up a swinging dart at the end of a thin string that embeds into a small block of wood that continues to swing after impact. The measurements are essentially the same as described below. In all cases, the “ball” is the dart, and the “catcher” is the block of wood with the dart embedded.)

To check the ball’s velocity, the catching device can be removed and the ball fired horizontally to find the horizontal displacement of the ball when it hits the floor. Projectile motion equations can be used to calculate the launch speed of the ball to check against the value determined by the ballistic method.

Since this device is fairly expensive, there are a couple of ways to make this a hands-on student lab rather than a teacher demonstration: (1) Split up measurement, recording, and calculation tasks among all students in the class. Put all data up on the board or a screen, and assign the final calculations to students. (2) Put this experiment into a rotation of four or five experiments, with student groups rotating from one station to another to use the equipment at each station.

Because of the complexity of the calculations, it’s a good idea to derive the “super formulas” in class prior to having the students perform the experiment.

Assessment

Question 1 on the 1999 AP Physics C Released Exam would be valuable as an assessment of students’ ability to design a laboratory experiment to answer a similar question.

Students’ answers to the analysis questions should be discussed clearly in the laboratory journal. This provides the opportunity for teachers to evaluate students’ written expression of their understanding of concepts.

Reflection

Students will be challenged by this lab, but they will gain a greater understanding of conservation of energy in various forms. Students also enjoy doing a “ballistics test” and comparing the velocity of the ball determined by this method to the velocity determined by projectile methods learned earlier in the course. This lab is versatile in that the teacher may choose to assign a simpler determination for first-year students using linear momentum and energy conservation or to fully develop the assumption of angular momentum. In the latter assumption, the experiment includes reinforcement of a broad

set of physics concepts, including linear momentum, angular momentum, center of mass, period of oscillation, projectile motion, and gravitational potential energy of a pendulum.

Summary

The ballistic pendulum uses conservation principles to determine the velocity of a projectile, reinforcing a broad set of physics concepts. Related calculations can be simplified (using several assumptions) to linear momentum and translational kinetic energy for first-year students. Higher order mathematical skills can also be utilized if the derivations include applications of rotational motion and concepts related to a compound pendulum.

Appendix J

Student Lab: Rotational Kinetic Energy

(Recommended time: one class period)

A commercially available rotating table with a computer-interface pulley that makes measurements of motion can be used to determine the moment of inertia of a solid disk by using calculations of changes in gravitational potential energy and translational kinetic energy of a falling mass to determine the rotational kinetic energy of the disk.

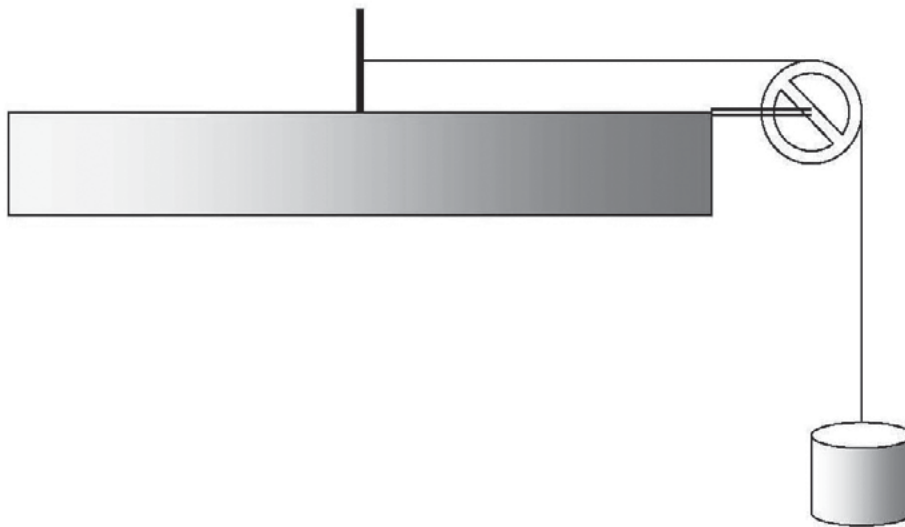

Figure 23

The commercial apparatus consists of a very low-friction turntable and a low-friction pulley. The pulley is connected via a photogate to a computer interface that uses the rate at which the pulley breaks a beam to plot the linear speed of the string as the mass falls. From this, students can select data for displacement, linear speed, or linear acceleration of the system. It is left to the students to make additional measurements as needed to determine the moment of inertia of the rotating disk.

Recommended Analysis Questions

- Create a graph from your data that shows the relationship between torque applied to the disk and the angular acceleration of the disk. How would this graph vary if a second identical disk is stacked on the first one?
- How does the moment of inertia vary with speed of rotation?
- If the string stretched slightly as higher masses are added, how would that affect your results?
- Why might it be best to wait a few moments after the apparatus starts rotating to take acceleration data measurements?

Teacher Notes

This experiment can be set up without the commercial equipment by using a turntable, pulley, and mass system. Students need to use timing methods to determine the rate at which the mass falls in order to determine acceleration.

One method students may choose is to select the data for speed of the string just before the mass hits the floor. They will then measure the distance the mass has fallen to determine the change in gravitational potential energy and final speed to calculate the kinetic energy of the mass just before it hits the floor. The same linear speed can be used ($v = \omega r$) with the radius of the post around which the string is wrapped on the disk to determine angular velocity of the disk. Conservation of energy can then be used to determine the moment of inertia of the disk. Encourage students to run multiple trials with different masses to find the result from an average.

A second method students may choose is to select the data for acceleration of the mass attached to the string to determine the tension in the string. That tension, along with the radius of the post around which the string is wrapped, can be used to calculate the torque on the disk. Using $\tau = I\alpha$ (where $a = \alpha r$), the moment of inertia can be calculated or used to check results from the previous method.

Assessment

Students' responses to the recommended analysis questions should be incorporated into the laboratory journal analysis, along with the students' own observations and conclusions. The teacher can evaluate students' understanding of concepts by reading the journals and commenting or making corrections. The teacher can also draw general conclusions from reading the journals to prompt a summative classroom discussion on common errors or misconceptions found in the journal analyses.

Reflection

Using commercially available equipment with the low-friction pulley interface, students obtain very precise results for the comparison of one rotating disk and two rotating disks. The calculations include both rotational and translational motion, relating those concepts both visually and mathematically for students. Alternatively, the methods described can be applied to a simpler (less expensive) device, with students using analog methods to determine the acceleration of the falling mass. Results might be less consistent, but the concepts could be reinforced at a lower cost. Students might even be involved in the design and construction of such a device for low-cost available materials.

Summary

This student laboratory activity uses the rotational motion device with computer interface to gather data for rotational motion of a disk. Conceptually, the activity is important in demonstrating the relationship between linear and angular acceleration.

About the Contributor

Connie Wells is a physics and AP Physics teacher, as well as a Science Olympiad team coach, at Pembroke Hill School in Kansas City, Mo. From 1995 to 2007, she served as a Reader, Table Leader, and Question Leader for the AP Physics Exam and was also a member of the AP Physics Development Committee from 1997 to 2001. In November 2003, Wells was a regional winner of the 2003-04 Siemens Awards for Advanced Placement® teachers sponsored by the College Board and the Siemens Foundation. She is the author of *AP Physics B*, 2nd edition, a companion review guide for Walker's *Physics*, 4th edition, published by Pearson/Prentice Hall in 2009. She previously authored *Kaplan's AP Physics B: A Study Guide*, published by Simon and Schuster in 2002 and 2003, and contributed the article "Electric Potential and Potential Energy" for the College Board's *AP Physics — Special Focus: Electrostatics* in 2007. As a workshop leader and a College Board consultant, she has presented at teacher workshops and institutes throughout the country and abroad — including sessions in Hawaii, Thailand, Colombia, Saipan, and Macedonia. Wells was appointed by the College Board to the AP Physics Redesign Commission in 2006 and serves as co-chair of the AP Physics Curriculum Development and Assessment Committee for AP Physics.



CM11PHYHB17300